

**CONSOLIDATED MOSQUITO ABATEMENT DISTRICT**  
13151 E. Industrial Dr., Parlier, CA 93648

**TELECONFERENCE DIAL-IN NUMBER**  
**(508)924-5256**

**- or -**

**VIDEO CONFERENCE**  
**<https://join.freeconferencecall.com/cmad>**  
**Online meeting ID: cmad**

**AGENDA**

**BOARD OF TRUSTEES MEETING 1:00 PM**

**August 16, 2021**

**1. ROLL CALL:**

**2. INTRODUCTION OF VISITORS:**

The public may address the Board on each agenda item during consideration of that item.

**3. PUBLIC COMMENTS:**

This is an opportunity for public comment on non-agenda items. The President reserves the right to limit the duration of each speaker to five (5) minutes. It is the policy of the Board not to answer any questions impromptu.

**4. APPROVAL OF JULY MINUTES:**

**5. APPROVAL OF JULY PAYROLL:**

**6. APPROVAL OF JULY BILLS:**

**7. SALE OF SURPLUS VEHICLES:**

The Board will open bids received and consider the sale of one 2003 Ford F250 truck, one 2005 Ford F150 truck, one 2006 Chevrolet Silverado truck, one 2007 Chevrolet Colorado 4WD truck and two 2009 Chevrolet Colorado 4WD trucks.

8. **QUARTERLY INVESTMENT REPORT:**  
The Manager will submit an investment report for the quarter ending June 30, 2021.
  
9. **EXPENSE REIMBURSEMENT DISCLOSURE REPORT:**  
The Manager will present the annual expense reimbursement disclosure report to the Board.
  
10. **PURCHASE OF ICE MACHINE:**  
The Board will be asked to approve the purchase of a commercial ice machine for the Clovis Depot.
  
11. **EMPLOYEE APPRECIATION LUNCH:**  
The Board will be asked to approve expenditure of funds for an employee appreciation lunch.
  
12. **DISTRICT PARTICIPATION AT MEETINGS:**  
The Board will be asked to authorize District participation at the following meetings:
  - a. Manager to attend the Northwest Mosquito and Vector Control Association meeting in Boise, Idaho, on October 5 – 8, 2021; and
  - b. Science Education Coordinator Ramirez to attend the MVCAC fall meeting in Costa Mesa, CA, on October 26 – 28, 2021.
  
13. **PREPARATION FOR ANNIVERSARY:**  
The Board will consider preparations for the celebration of the District's 75<sup>th</sup> anniversary.
  
14. **BOARD GENERAL DISCUSSION:**  
This is an opportunity for Board Members to ask questions for clarification, provide information to staff, request staff to report back on a matter or direct staff to place a matter on a subsequent agenda.
  
15. **STAFF REPORTS:**  
This is an opportunity for staff to report on District activities.
  
16. **ADJOURNMENT:**

**MINUTES OF THE BOARD OF TRUSTEES OF  
THE CONSOLIDATED MOSQUITO ABATEMENT DISTRICT  
JULY 19, 2021**

The regular meeting of the Board of Trustees of the Consolidated Mosquito Abatement District was held at the District Office, in Parlier, and by teleconference at 1:00 PM on July 19, 2021.

**1. Roll Call:**

**Trustees Present at the Parlier Office:**

Tok Fukuda	Kingsburg
Charles Lockhart	Orange Cove
Joe Reyna	Parlier
Bruce Taylor	County of Fresno

**Trustees Present by Teleconference:**

Peggy Brisendine	Fresno
David Cardenas	Fowler
Pete Esraelian	Selma
Mary Anne Hill	County of Fresno
Dan Munk	Reedley
Karen Steinhauer	Sanger

**Trustee Vacancy:**

Vacant	Clovis
--------	--------

**Others Present at the Parlier Office:**

Steve Mulligan	District Manager
Karan Cox	Office Administrator

**Others Present by Teleconference:**

Joseph Walton	Vehicle bidder
---------------	----------------

**2. President Fukuda called the meeting to order at 1:07 PM:**

**3. Public Comments:** None.

**4. Approval of June Minutes:** A motion was made by Trustee Reyna, seconded by Trustee Lockhart and passed by 10 – 0 roll call vote to approve the minutes of the June 21, 2021 Board meeting.

5. **Approval of June Payroll:** A motion was made by Trustee Taylor, seconded by Trustee Esraelian and passed by 10 – 0 roll call vote to approve the June payroll checks having District numbers, 26193 – 26232, 26245 – 26247, 26249 – 26292 and 26301 – 26302 in the total amount of \$147,158.46.
  
6. **Approval of June Bills:** A motion was made by Trustee Lockhart, seconded by Trustee Cardenas and passed by 10 – 0 roll call vote to approve the June commercial checks having District numbers, 26159, 26232 – 26245, 26248, 26289 – 26290, 26293 – 26300 and 26302 – 26336 in the total amount of \$145,863.63.
  
7. **Sale of Surplus Vehicles:** Sealed bids for the sale of one 1999 Ford F150 truck, one 2004 Ford F150 truck, two 2007 Chevrolet Colorado 4WD trucks and one 2009 Chevrolet Colorado 4WD truck were received and opened. These bids are listed in Attachment A. A motion was made by Trustee Taylor, seconded by Trustee Esraelian and passed by 10 – 0 roll call vote to accept the highest, qualified bid for each vehicle, as determined by the District Manager.
  
8. **Disposition of Surplus Vehicles:** A motion was made by Trustee Reyna, seconded by Trustee Taylor and passed by a 10 – 0 roll call vote to declare as surplus property and to sell one 2003 Ford F250 (VIN 3FTNF20L33MB24842), one 2005 Ford F150 (VIN 1FTRF12W85NC02009), one 2006 Chevrolet Silverado (VIN 1GCDDT14E978206935), one 2007 Chevrolet Colorado 4WD (VIN 1GCDDT14E978206935), one 2009 Chevrolet Colorado 4WD (VIN 1GCDDT14E898145466) and one 2009 Chevrolet Colorado 4WD (VIN 1GCDDT14EX98146604).  
  
A motion was made by Trustee Lockhart, seconded by Trustee Cardenas and passed by 9 – 1 roll call vote (Taylor opposed) to direct the Equipment Committee, the Manager and the Mechanic to set a minimum sale price for each vehicle and to advertise and sell the vehicles by sealed bids to the highest bidders.
  
9. **Closed Session: Conference with Real Property Negotiator under Government Code Section 54956.8.**
  - a. **Property: 1325 I Street, Reedley, CA; APN 368-271-11T.**
  - b. **Agency Negotiator: Steve Mulligan.**
  - c. **Negotiating Parties: Consolidated Mosquito Abatement District and Samuel A. Escobar and Valerie G. Escobar, Prospective Buyers.**
  - d. **Under Negotiation: Price and Terms of Sale.**

10. **Report out of Closed Session:** A motion was made by Trustee Cardenas, seconded by Trustee Hill and passed by a 10 – 0 roll call vote to approve the sale of the Reedley Depot property, 1325 I Street, Reedley, APN 368-271-11T, by approving the Purchase and Sale Agreement with Samuel and Valerie Escobar for \$185,000 and to authorize both the Board President and/or District Manager to execute the Agreement, the Deed, escrow instructions and all documents necessary to facilitate the sale of the property and to close escrow.
  
11. **Employee Medical Health Benefits Plan:** A motion was made by Trustee Reyna, seconded by Trustee Esraelian and passed by a 10 – 0 roll call vote to approve payment of full premiums and Health Savings Account contributions for regular employees, spouses and qualifying dependents for selected medical health plans through the Special District Risk Management Authority. Selected plans offered by the District are Blue Shield Anthem Blue Cross HDHP 20, Blue Shield Silver PPO and Kaiser HMO 20.

The District provides dental and vision benefits to regular employees through the Central California Vector Control Joint Powers Agency.

12. **Purchase of Heavy-Duty Trailer:** Price quotations for the purchase of a heavy-duty trailer were received from Carson Trailers and Big Tex Trailers. A motion was made by Trustee Lockhart, seconded by Trustee Esraelian and passed by 10 – 0 roll call vote to approve the purchase of a heavy-duty trailer from Carson Trailers for \$5,106.42.
  
13. **Preparation for Anniversary:** Trustee Cardenas left the meeting. The Manager discussed plans and preparations made by the staff anniversary planning committee and the Board was asked to review a tentative invitation list and to suggest additions.
  
14. **Board General Discussion:** President Fukuda read a letter dated July 14, 2021, from Karl Peterson to Clovis City Manager Luke Serpa stating that Mr. Peterson has resigned his appointment as trustee from the City of Clovis.  
  
Trustee Taylor asked whether any employees were currently working remotely. The Manager responded that none were.  
  
Trustee Taylor asked if there was progress in contracting a landscaper for the District facilities. The Manager responded that staff has been contacting prospective contractors.
  
15. **Staff Reports:** The Manager stated that CalPERS reported a preliminary 21.3% net return on investments for FY 2020 – 2021.

The Manager reported that a vehicle had crashed into and damaged the eastern property wall of the Clovis Depot and that it was repaired by District staff.

A Program Report on current activities was provided to the Board.

16. **Adjournment:** The meeting was adjourned at 3:18 PM. The next Board meeting will be held on Monday, August 16, 2021.

---

Mary Anne Hill  
Vice President/Secretary

## Attachment A

<u>Item No.</u>		<u>V.I.N.</u>	<u>Minimum Bid</u>
#1	1999 Ford F150 2WD	1FTRF17WXXKB35328	\$1,500.00
#2	2004 Ford F150 2WD	2FTRF17WX4CA51087	\$1,800.00
#3	2007 Chevrolet Colorado 4WD	1GCDT14EX78207317	\$1,750.00
#4	2007 Chevrolet Colorado 4WD	1GCDT14E078209948	\$1,750.00
#5	2009 Chevrolet Colorado 4WD	1GCDT14E898146343	\$2,000.00

<u>Item No.</u>	<u>Name of Buyer</u>	<u>Buyer Address</u>	<u>Purchase Price</u>
#1	GS Farms	PO Box 276, Cantua Creek CA 93608	\$3,500.00
#2	GS Farms	PO Box 276, Cantua Creek CA 93608	\$3,600.00
#3	GS Farms	PO Box 276, Cantua Creek CA 93608	\$3,500.00
#4	Joseph Walton	18928 Rd 400, Madera CA 93636	\$4,010.00
#5	James Greene	PO Box 262, Bass Lake CA 93604	\$4,659.00

**Consolidated Mosquito Abatement District  
Sale of Surplus Vehicles**

<b>Name of Bidder</b>	<b>Date of Bid</b>	<b>Time of Bid</b>	<b>Item # 1 Bid Amount</b>	<b>Item # 2 Bid Amount</b>	<b>Item # 3 Bid Amount</b>	<b>Item # 4 Bid Amount</b>	<b>Item # 5 Bid Amount</b>
Renee Ramos	6/29/21	11:24am			\$2,500.00		
Javier Del Rio Jr.	6/29/21	3:31pm			\$1,850.00	\$1,850.00	
Javier Sandoval	6/30/21	9:00am			\$1,905.00	\$1,905.00	\$2,805.00
Gabriel Laguna	6/30/21	12:08pm	\$1,951.00	\$2,100.00		\$2,150.00	\$2,651.00
Chris Adolph	6/30/21	1:22pm	\$1,750.00	\$2,001.00	\$2,001.00	\$2,001.00	\$2,250.00
Edward Martinez	6/30/21	4:22pm	\$1,700.00	\$1,900.00	\$1,900.00	\$1,950.00	\$2,200.00
Mike Amaya	7/1/21	8:00am	\$1,700.00	\$1,800.00	\$1,750.00	\$1,751.00	\$2,300.00
Nate Boynton	7/1/21	8:00am	\$1,900.00	\$2,200.00		\$2,200.00	\$2,400.00
Joaquin Bora?	7/1/21	10:37am					\$2,300.00
Renee Ramos	7/1/21	10:58am					\$2,875.00
Joseph Avalos	7/1/21	2:30pm				\$2,000.00	
Jose Lua	7/2/21	8:35am					\$2,500.00
Juan Sanchez	7/2/21	9:07am	\$2,000.00	\$2,100.00	\$2,100.00	\$1,950.00	\$2,500.00
Bill Tischler	7/2/21	10:00am	\$1,751.00	\$2,201.00			\$2,301.00
Marino Vargas	7/2/21	11:38am	\$1,600.00	\$1,900.00	\$1,850.00	\$1,900.00	\$2,100.00
Paulino Vargas	7/2/21	11:38am	\$1,600.00	\$1,900.00	\$1,850.00	\$1,850.00	\$2,500.00
Jarnail Singh	7/2/21	11:53am					\$2,500.00
Jesus Gonzalez	7/2/21	12:20pm					\$3,900.00
Alberto Horta	7/2/21	2:30pm					\$3,081.00
Nicholas Bazaldua?	7/6/21	8:40am					\$2,500.00



**Consolidated Mosquito Abatement District  
Sale of Surplus Vehicles**

<b>Name of Bidder</b>	<b>Date of Bid</b>	<b>Time of Bid</b>	<b>Item # 1 Bid Amount</b>	<b>Item # 2 Bid Amount</b>	<b>Item # 3 Bid Amount</b>	<b>Item # 4 Bid Amount</b>	<b>Item # 5 Bid Amount</b>
Miguel Rodriguez	7/6/21	1:03pm				\$1,900.00	\$2,200.00
Santokh Dhillon	7/6/21	1:33pm			\$2,500.00	\$2,500.00	\$2,800.00
Jessica Phillips	7/6/21	2:06pm		\$1,900.67		\$2,150.67	\$2,800.67
Brandon Bailey	7/6/21	2:09pm		\$2,100.00		\$2,450.00	\$3,200.00
Christopher Routen	7/6/21	3:10pm			\$3,501.00	\$3,001.00	\$3,801.00
Rudy Herrera	7/6/21	4:15pm			\$2,500.00	\$2,500.00	\$3,500.00
James John Diaz	7/7/21	9:49am	\$2,010.00	\$2,505.00			
Miguel Rodriguez	7/7/21	10:41am	\$1,650.00	\$1,950.00			
Federico Martin	7/7/21	2:35pm		\$2,000.00			
Paul Ramirez	7/8/21	11:38am					\$2,455.00
Steve Dominguez	7/8/21	11:53am	\$1,995.00	\$2,161.00	\$2,600.00	\$2,600.00	\$3,140.00
GS Farms - Susan Rusconi	7/8/21	2:11pm	\$3,500.00	\$3,600.00	\$3,500.00	\$3,800.00	\$4,100.00
Jay Blanchard	7/9/21	8:26am			\$2,000.00	\$1,950.00	\$2,200.00
Juan Andrade	7/9/21	12:20pm					\$2,050.00
Joseph Walton	7/9/21	1:11pm		\$2,428.99		\$2,383.99	
Victor Alvarez	7/9/21	1:45pm	\$1,600.00	\$2,000.00	\$1,800.00	\$2,000.00	\$2,200.00
Jose Montemayor	7/12/21	8:35am	\$3,500.00	\$2,500.00	\$3,500.00	\$3,000.00	\$3,500.00
Fred Johnson	7/12/21	10:15am	\$2,872.00	\$3,477.00	\$2,853.00	\$3,489.00	\$3,650.00
Bernardo Trujillo	7/12/21	12:04pm	\$1,900.00	\$2,350.00			\$3,200.00
George Moreno	7/13/21	8:45am	\$1,700.00	\$2,100.00			

**Consolidated Mosquito Abatement District  
Sale of Surplus Vehicles**

<b>Name of Bidder</b>	<b>Date of Bid</b>	<b>Time of Bid</b>	<b>Item # 1 Bid Amount</b>	<b>Item # 2 Bid Amount</b>	<b>Item # 3 Bid Amount</b>	<b>Item # 4 Bid Amount</b>	<b>Item # 5 Bid Amount</b>
Alejo Landeros Sr.	7/13/21	12:22pm			\$2,000.00	\$2,000.00	\$3,000.00
Ronnie Blunt	7/13/21	3:13pm	\$1,650.00				
Kulwant Gill	7/14/21	3:15pm			\$2,800.00	\$2,700.00	\$3,000.00
Terry Hathaway	7/14/21	3:45pm	\$1,701.00	\$2,001.00	\$2,675.00	\$2,829.00	\$3,105.00
Francis Bonilla Zendegas	7/15/21	2:20pm	\$1,800.00	\$2,300.00	\$2,000.00	\$2,000.00	
Jesus Gonzalez	7/15/21	3:06pm			\$2,500.00		\$4,500.00
Gabe Verduzco	7/15/21	3:18pm				\$1,900.00	\$2,555.00
Frank Gastelum	7/16/21	8:00am		\$2,385.00	\$2,385.00		
Alfred de la Cruz	7/16/21	9:13am	\$1,800.00	\$2,500.00			
Joe Delgado	7/16/21	9:28am		\$2,500.00			
Benny Tomasetti	7/16/21	2:15pm	\$1,700.00	\$1,995.00	\$1,995.00	\$1,995.00	\$2,200.00
Harold Hudiburgh	7/16/21	2:48pm	\$1,610.00		\$2,111.10	\$2,111.02	\$2,221.01
Larry Marjolejo	7/16/21	3:40pm			\$2,350.00	\$2,350.00	
Richard Roberts	7/19/21	8:35am	\$1,801.00			\$2,505.00	\$2,501.00
Victor Guillen	7/19/21	9:32am				\$3,100.00	
Alicia Mueller	7/19/21	10:28am			\$1,801.01	\$2,029.03	\$2,606.06
Joseph Walton	7/19/21	11:02am			\$3,003.00	\$4,010.00	
Ron Evans	7/19/21	11:11am			\$2,221.00	\$2,132.00	\$3,877.00
James Greene	7/19/21	12:10pm			\$4,159.00	\$4,159.00	\$4,659.00
Dennis DeRose	7/19/21	1:47pm	\$2,101.00			\$2,501.00	

**Consolidated Mosquito Abatement District  
Payroll Expenses  
July 2021**

<b>Check #</b>	<b>Gross Pay</b>	<b>Net Pay</b>	<b>Payee</b>	<b>Description</b>
26337	\$1,447.88	\$1,202.35	Adolfo Mendez	Seasonal Employee
26338	\$2,603.50	\$1,750.74	Amy Garcia	Full-Time Employee
26339	\$2,112.00	\$1,559.28	Anita Munoz	Seasonal Employee
26340	\$1,140.00	\$968.57	Arthur Velasco	Seasonal Employee
26341	\$1,496.00	\$1,239.68	Bobby Torres	Seasonal Employee
26342	\$2,861.00	\$1,936.24	Brittany Deegan	Full-Time Employee
26343	\$300.00	\$277.05	Bruce Taylor	Trustee
26344	\$1,540.00	\$1,278.05	Capital Moua	Seasonal Employee
26345	\$300.00	\$277.05	Charles Lockhart	Trustee
26346	\$1,540.00	\$1,278.05	Cheng Vang	Seasonal Employee
26347	\$2,861.00	\$2,064.92	Chris Monis	Full-Time Employee
26348	\$1,628.00	\$1,468.48	Clarita Ramblas	Seasonal Employee
26349	\$2,417.00	\$1,729.78	Conner Schaak	Full-Time Employee
26350	\$300.00	\$277.05	Dan Munk	Trustee
26351	\$300.00	\$277.05	David Cardenas	Trustee
26352	\$1,402.50	\$1,168.43	David Rodriguez	Seasonal Employee
26353	\$3,086.50	\$2,249.51	Derek Hill	Full-Time Employee
26354	\$2,631.00	\$1,813.82	Devon Cornel	Full-Time Employee
26355	\$2,291.38	\$1,769.74	Donald McNiell	Seasonal Employee
26356	\$1,376.00	\$1,148.14	Elijah Bojorquez	Seasonal Employee
26357	\$1,628.00	\$1,260.48	Eric Ferguson	Seasonal Employee
26358	\$2,861.00	\$2,140.05	Gha Vang	Full-Time Employee
26359	\$1,461.25	\$1,328.48	Heidi Hubbard	Seasonal Employee
26360	\$1,716.00	\$1,459.14	Jacob Uribe	Seasonal Employee
26361	\$1,408.00	\$1,172.29	Jason Blackmon	Seasonal Employee
26362	\$1,394.25	\$1,287.58	Jesse Hernandez	Seasonal Employee
26363	\$4,698.00	\$3,000.59	Jodi Holeman	Full-Time Employee
26364	\$300.00	\$277.05	Joe Reyna	Trustee
26365	\$2,861.00	\$1,692.65	Jose Moreno	Full-Time Employee
26366	\$2,417.00	\$1,696.47	Jovana Benavides	Full-Time Employee
26367	\$1,496.00	\$1,239.68	Justin Lor	Seasonal Employee
26368	\$3,154.00	\$2,070.31	Karan Cox	Full-Time Employee
26369	\$300.00	\$277.05	Karen Steinhauer	Trustee
26370	\$300.00	\$277.05	Karl Peterson	Trustee
26371	\$3,947.50	\$2,459.94	Katherine Ramirez	Full-Time Employee
26372	\$1,332.00	\$1,230.10	Lewis Nunes	Seasonal Employee
26373	\$300.00	\$277.05	Mary Anne Hill	Trustee
26374	\$1,540.00	\$1,272.37	Melissa Thies	Seasonal Employee
26375	\$2,012.50	\$1,673.59	Michael Scotty Dunn	Seasonal Employee
26376	\$1,152.00	\$978.11	Oscar Garcia	Seasonal Employee

**Consolidated Mosquito Abatement District  
Payroll Expenses  
July 2021**

<b>Check #</b>	<b>Gross Pay</b>	<b>Net Pay</b>	<b>Payee</b>	<b>Description</b>
26377	\$200.00	\$184.70	Peggy Brisendine	Trustee
26378	\$300.00	\$277.05	Pete Esraelian	Trustee
26379	\$1,535.63	\$1,269.52	Ricardo Garcia	Seasonal Employee
26380	\$1,540.50	\$1,216.88	Robert Martinez	Seasonal Employee
26381	\$1,540.00	\$1,367.30	Roger Vang	Seasonal Employee
26382	\$1,716.00	\$1,287.82	Ronnie Blunt	Seasonal Employee
26383	\$6,600.00	\$4,395.33	Steve Mulligan	Full-Time Employee
26384	\$300.00	\$277.05	Tokuo Fukuda	Trustee
26385	\$1,716.00	\$1,293.50	Tracy Autrey	Seasonal Employee
26386	\$1,400.00	\$1,166.24	Tuacheng Vang	Seasonal Employee
26411	\$1,452.00	\$1,205.97	Adolfo Mendez	Seasonal Employee
26412	\$2,603.50	\$1,750.74	Amy Garcia	Full-Time Employee
26413	\$2,112.00	\$1,559.26	Anita Munoz	Seasonal Employee
26414	\$592.00	\$539.71	Arthur Velasco	Seasonal Employee
26415	\$1,360.00	\$1,136.06	Bobby Torres	Seasonal Employee
26416	\$2,861.00	\$1,936.23	Brittany Deegan	Full-Time Employee
26417	\$1,540.00	\$1,278.05	Capital Moua	Seasonal Employee
26418	\$1,540.00	\$1,278.05	Cheng Vang	Seasonal Employee
26419	\$2,861.00	\$2,064.91	Chris Monis	Full-Time Employee
26420	\$1,628.00	\$1,468.50	Clarita Ramblas	Seasonal Employee
26421	\$2,417.00	\$1,729.79	Conner Schaak	Full-Time Employee
26422	\$1,427.25	\$1,187.20	David Rodriguez	Seasonal Employee
26423	\$3,086.50	\$2,247.00	Derek Hill	Full-Time Employee
26424	\$2,631.00	\$1,813.83	Devon Cornel	Full-Time Employee
26425	\$2,291.38	\$1,769.72	Donald McNiel	Seasonal Employee
26426	\$1,244.00	\$1,048.03	Elijah Bojorquez	Seasonal Employee
26427	\$1,628.00	\$1,260.49	Eric Ferguson	Seasonal Employee
26428	\$2,861.00	\$2,140.28	Gha Vang	Full-Time Employee
26429	\$1,225.00	\$1,120.70	Heidi Hubbard	Seasonal Employee
26430	\$1,696.50	\$1,442.88	Jacob Uribe	Seasonal Employee
26431	\$1,408.00	\$1,172.27	Jason Blackmon	Seasonal Employee
26432	\$1,023.00	\$944.75	Jesse Hernandez	Seasonal Employee
26433	\$4,698.00	\$3,000.81	Jodi Holeman	Full-Time Employee
26434	\$2,861.00	\$1,692.41	Jose Moreno	Full-Time Employee
26435	\$2,417.00	\$1,696.48	Jovana Benavides	Full-Time Employee
26436	\$1,496.00	\$1,239.68	Justin Lor	Seasonal Employee
26437	\$3,154.00	\$2,070.31	Karan Cox	Full-Time Employee
26438	\$3,947.50	\$2,460.41	Katherine Ramirez	Full-Time Employee
26439	\$1,184.00	\$1,093.42	Lewis Nunes	Seasonal Employee
26440	\$1,540.00	\$1,272.37	Melissa Thies	Seasonal Employee

**Consolidated Mosquito Abatement District  
Payroll Expenses  
July 2021**

<b>Check #</b>	<b>Gross Pay</b>	<b>Net Pay</b>	<b>Payee</b>	<b>Description</b>
26441	\$2,075.00	\$1,716.34	Michael Scotty Dunn	Seasonal Employee
26442	\$1,540.00	\$1,272.37	Ricardo Garcia	Seasonal Employee
26443	\$1,404.00	\$1,117.02	Robert Martinez	Seasonal Employee
26444	\$1,540.00	\$1,367.30	Roger Vang	Seasonal Employee
26445	\$1,686.75	\$1,268.77	Ronnie Blunt	Seasonal Employee
26446	\$6,600.00	\$4,395.34	Steve Mulligan	Full-Time Employee
26447	\$1,340.63	\$1,037.52	Tracy Autrey	Seasonal Employee
26448	\$1,260.00	\$1,060.11	Tuacheng Vang	Seasonal Employee
<b>Total</b>	<b>\$166,992.40</b>	<b>\$125,394.48</b>		

**Employee Deductions and Liabilities**

<b>Check #</b>	<b>Amount</b>	<b>Payee</b>	<b>Description</b>
26387	\$2,549.40	EDD	State Income Tax
26389	\$13,707.27	CMAD	Federal, Social Security, Medicare
26390	\$3,804.77	CalPERS	Retirement
26391	\$785.00	ICMA	457K Retirement
26392	\$200.00	Valley First Credit Union	Credit Union
26449	\$2,463.53	EDD	State Income Tax
26450	\$12,983.70	CMAD	Federal, Social Security, Medicare
26451	\$3,770.14	CalPERS	Retirement
26452	\$785.00	ICMA	457K Retirement
26453	\$200.00	Valley First Credit Union	Credit Union
26454	\$197.68	Aflac	Disability Insurance
26466	\$151.43	Mutual of Omaha	Life Insurance
<b>Total Deductions</b>	<b>\$41,597.92</b>		
<b>Total Net Pay</b>	<b>\$125,394.48</b>		
<b>Total Gross Pay</b>	<b>\$166,992.40</b>		

**Consolidated Mosquito Abatement District  
Maintenance and Operations Expenses  
July 2021**

**Bank of the West Checks**

<b>Check #</b>	<b>Amount</b>	<b>Payee</b>	<b>Description</b>
26388	\$9,117.95	EDD	Unemployment Insurance
26389	\$6,650.27	CMAD	District Social Security & Medicare
26390	\$4,587.91	CalPERS	District Retirement
26393	\$750.00	Derek Hill	H S A Deductible - 3rd Quarter
26394	\$197.66	AT&T	Telephone
26395	\$418.39	AT&T	Telephone
26396	\$534.00	Jim's Plumbing	Back-Flow Testing
26397	\$253.00	Matson Alarm Co.	Alarm Systems
26398	\$636.94	City of Parlier	Water Sewer Disposal
26399	\$2,640.94	PG&E	Heat Light Power
26400	\$35.32	Republic Services	Disposal
26401	\$102.08	City of Sanger	Water Sewer Disposal
26402	\$12,123.10	SDRMA	Health Insurance Premium
26403	\$206.10	Slaven's Radiator	Vehicle Repairs
26404	\$96.96	SoCal Gas	Heat
26405	\$300.00	Streamline	Website Design & Maintenance
26406	\$146,491.00	Vector Control JPA	Property, Auto & Worker's Comp Insurance
26407	\$2,836.83	Verizon Wireless	Cell Phone & Tablet Service
26408	\$750.00	Chris Monis	H S A Deductible - 3rd Quarter
26409	\$1,500.00	Jose Moreno	H S A Deductible - 3rd Quarter
26410	\$7,500.00	Premier Valley Bank	H S A Deductible - 3rd Quarter
26450	\$6,152.70	CMAD	District Social Security & Medicare
26451	\$4,545.81	CalPERS	District Retirement
26455	\$842.96	AT&T	Telephone - 800 number
26456	\$258.88	AT&T	Telephone - Parlier
26457	\$882.85	AT&T	Internet - Parlier
26458	\$405.07	AT&T	Phone / Internet - Clovis
26459	\$106.60	California Water Service	Water
26460	\$2,600.00	Carson Trailer	50% Deposit on a New Trailer
26461	\$11,400.00	ESRI, Inc.	ArcGIS Maintenance
26462	\$174.93	PG&E	Heat Light Power
26463	\$54.79	City of Reedley	Water Sewer
26464	\$39.29	Waste Management	Disposal
26466	\$16.63	Mutual of Omaha	Life Insurance
26467	\$300.00	All-Pro Janitorial	Janitorial Services
26468	\$12.03	AutoZone, Inc.	Repair Parts
26469	\$83.82	Battery Systems, Inc.	Battery
26470	\$161.22	California Industrial Rubber	Hip Boots
26471	\$907.88	Central California VCJPA	Dental / Vision Premium
26472	\$3,210.98	CitiBusiness Card	Field Equip / Safety Equip / Misc Expenses
26473	\$55,531.82	Clarke Mosquito Control	Insecticides

**Consolidated Mosquito Abatement District  
Maintenance and Operations Expenses  
July 2021**

<b>Check #</b>	<b>Amount</b>	<b>Payee</b>	<b>Description</b>
26474	\$41.95	DoorKing, Inc.	Gate Service
26475	\$147.78	East Bay Tire Co.	Tires
26476	\$487.24	Ernest Packaging Solutions	Misc Operating Supplies
26477	\$130.87	FedEx	Mosquito Sample Shipping
26478	\$72.72	County of Fresno	GIS License
26479	\$37.84	Home Depot	Field Equipment
26480	\$1,706.87	Jorgensen Company	Safety Equipment
26481	\$31.50	Lee's Service	Tire Disposal
26482	\$540.04	Mission Uniform Service	Uniforms & Safety
26483	\$4,136.00	MVCAC	Mosquito Testing
26484	\$10,500.00	MVCAC	Yearly Dues
26485	\$307.37	Napa	Lubricants / Repair Parts
26486	\$310.79	Nelson's Ace Hardware & Lumber	Field Equip / Shop Supplies / Misc Supplies
26487	\$174.75	Office Depot	Misc Office Supplies
26488	\$975.58	O'Reilly Auto Parts	Repair Parts
26489	\$93.30	PBM Supply & Mfg	Field Equipment
26490	\$1,708.78	Praxair Distribution, Inc.	Dry Ice
26491	\$471.99	SPEX Sample Prep	Surveillance Supplies
26492	\$790.84	Starace Mechanical Heating & AC	A/C Repair - Lab & Computer Room
26493	\$9,241.08	Target Specialty Products	Insecticides
26494	\$184.15	Terminal Air Brake Supply	Repair Parts
26495	\$52.85	Uline	Bio-Assay Jars
26496	\$17,855.05	Valero	Fuel
26497	\$2,421.21	Verizon Wireless	Cell Phones / Tablets
26498	\$128.07	Wizix Technology Group	Copier Maintenance
<b>Total</b>	<b>\$337,965.33</b>		

**County of Fresno Checks**

<b>Check #</b>	<b>Amount</b>	<b>Payee</b>	<b>Description</b>
295060	\$274,564.29	Consolidated Mosquito	Transfer funds to checking
295061	\$116,999.78	Consolidated Mosquito	Transfer funds to checking
295062	\$113,242.14	Consolidated Mosquito	Transfer funds to checking
	<b>\$504,806.21</b>		

**Summary of July Expenses**

June Over-Payment Check # 26145	(\$469.21)
August Expense (Elijah Bojorquez) - Check # 26465	\$317.69
July 2021 Salaries & Wages	\$166,992.40
July 2021 Maintenance & Operations	\$337,965.33
<b>Total July 2021 Expenditures</b>	<b>\$504,806.21</b>

## Consolidated Mosquito Abatement District Monthly Expenditures

ACCOUNT NUMBER	ACCOUNT NAME	BUDGET FY 2021/2022	SPENT TO DATE	BALANCE JULY 31, 2021
<b><u>SALARIES, WAGES &amp; EMPLOYEE BENEFITS</u></b>				
6101-01	Salaried Wages	\$1,150,000.00	\$89,197.00	\$1,060,803.00
6101-06	Hourly Wages & Extra Help	\$615,000.00	\$78,139.40	\$536,860.60
6101-02	FICA Employers Contribution	\$135,000.00	\$15,666.11	\$119,333.89
6101-03	Unemployment Insurance	\$24,000.00	\$1,100.07	\$22,899.93
6101-04	Retirement District's Payment	\$150,000.00	\$9,133.72	\$140,866.28
6101-05	Group Health Insurance	\$260,000.00	\$23,547.61	\$236,452.39
6101-07	Pre-Employment & Misc. Expenses	\$8,000.00	\$35.00	\$7,965.00
	<b>TOTALS</b>	<b>\$2,342,000.00</b>	<b>\$216,818.91</b>	<b>\$2,125,181.09</b>
<b><u>OPERATING &amp; MAINTENANCE SUPPLIES &amp; EXPENSE</u></b>				
6102-01	Insecticides & Herbicides	\$400,000.00	\$64,872.90	\$335,127.10
6102-02	Power Spray & Field Equipment	\$25,000.00	\$1,301.67	\$23,698.33
6102-03	Misc Operating Supplies & Expense	\$6,000.00	\$576.77	\$5,423.23
6102-04	Fish Program	\$10,000.00	\$104.69	\$9,895.31
6102-05	Building & Ground Maintenance	\$40,000.00	\$1,985.91	\$38,014.09
6102-06	Airplane Expense	\$3,000.00	\$0.00	\$3,000.00
	<b>TOTALS</b>	<b>\$484,000.00</b>	<b>\$68,841.94</b>	<b>\$415,158.06</b>
<b><u>MOTOR VEHICLE SUPPLIES &amp; EXPENSE</u></b>				
6103-01	Fuel & Lubricants	\$150,000.00	\$18,061.73	\$131,938.27
6103-02	Repairs & Shop Tools	\$45,000.00	\$1,505.66	\$43,494.34
6103-03	Tires & Batteries	\$12,000.00	\$263.10	\$11,736.90
	<b>TOTALS</b>	<b>\$207,000.00</b>	<b>\$19,830.49</b>	<b>\$187,169.51</b>
<b><u>UTILITIES &amp; COMMUNICATIONS</u></b>				
6104-01	Heat, Light & Power	\$40,000.00	\$2,912.83	\$37,087.17
6104-04	Water Sewer & Disposal	\$18,000.00	\$975.02	\$17,024.98
6105-01	Telephone	\$22,000.00	\$3,005.81	\$18,994.19
6105-02	Cellular Phones	\$22,000.00	\$2,421.21	\$19,578.79
	<b>TOTALS</b>	<b>\$102,000.00</b>	<b>\$9,314.87</b>	<b>\$92,685.13</b>
<b><u>OFFICE SUPPLIES &amp; EXPENSE</u></b>				
6106-02	Postage, Printing & Stationery	\$6,000.00	\$179.30	\$5,820.70
6106-04	Repairs & Maintenance	\$6,000.00	\$128.07	\$5,871.93
6106-05	Misc Office Supplies	\$13,000.00	\$416.70	\$12,583.30
6106-06	Office Equipment & Furniture	\$8,000.00	\$0.00	\$8,000.00
	<b>TOTALS</b>	<b>\$33,000.00</b>	<b>\$724.07</b>	<b>\$32,275.93</b>
<b><u>INSURANCE</u></b>				
6107-01	Liability, Property & Auto	\$87,000.00	\$78,740.00	\$8,260.00
6107-02	Workers Compensation	\$76,000.00	\$67,751.00	\$8,249.00
	<b>TOTALS</b>	<b>\$163,000.00</b>	<b>\$146,491.00</b>	<b>\$16,509.00</b>



**Consolidated Mosquito Abatement District  
Monthly Expenditures**

ACCOUNT NUMBER	ACCOUNT NAME	BUDGET FY 2020/2021	SPENT TO DATE	BALANCE JULY 31, 2021
<b><u>TRAVEL &amp; SUBSISTENCE EXPENSE</u></b>				
6108-01	Meetings & Travel Allowance	\$50,000.00	\$0.00	\$50,000.00
6108-02	Trustee Allowance	\$1,000.00	\$0.00	\$1,000.00
6108-03	Meal Allowance	\$5,000.00	\$44.47	\$4,955.53
	<b>TOTALS</b>	<b>\$56,000.00</b>	<b>\$44.47</b>	<b>\$55,955.53</b>
<b><u>MISCELLANEOUS EXPENDITURES</u></b>				
6109-01	Rent: Land, Buildings and Equipment	\$2,000.00	\$0.00	\$2,000.00
6109-02	Dues, Subscriptions and Fees	\$28,000.00	\$10,500.00	\$17,500.00
6109-03	Education & Publicity	\$30,000.00	\$463.29	\$29,536.71
6109-04	Accounting	\$14,000.00	\$0.00	\$14,000.00
6109-05	Legal	\$14,000.00	\$0.00	\$14,000.00
6109-06	County Service Charge	\$0.00	\$0.00	\$0.00
6109-07	Uniforms, Safety Apparel & Equipment	\$30,000.00	\$3,528.92	\$26,471.08
6109-08	Surveillance & Research	\$50,000.00	\$6,447.64	\$43,552.36
6109-09	Other Miscellaneous Expenditures	\$20,000.00	\$231.84	\$19,768.16
6109-10	GIS & GPS	\$60,000.00	\$11,472.72	\$48,527.28
	<b>TOTALS</b>	<b>\$248,000.00</b>	<b>\$32,644.41</b>	<b>\$215,355.59</b>
<b>TOTAL OPERATIONAL EXPENDITURES</b>		<b>\$3,635,000.00</b>	<b>\$494,710.16</b>	<b>\$3,140,289.84</b>
<b><u>CAPITAL OUTLAY</u></b>				
6110-01	Office & Lab Furniture & Equipment	\$15,000.00	\$0.00	\$15,000.00
6110-02	Auto Equipment	\$300,000.00	\$0.00	\$300,000.00
6110-03	Shop Equipment	\$10,000.00	\$0.00	\$10,000.00
6110-04	Field Equipment	\$20,000.00	\$2,600.00	\$17,400.00
6110-05	Building & Ground Improvement	\$50,000.00	\$0.00	\$50,000.00
6110-06	Loan & Lease Purchase Payments	\$290,000.00	\$0.00	\$290,000.00
	<b>TOTAL CAPITAL OUTLAY EXPENDITURES</b>	<b>\$685,000.00</b>	<b>\$2,600.00</b>	<b>\$682,400.00</b>
<b>TOTAL EXPENDITURES</b>		<b>\$4,320,000.00</b>	<b>\$497,310.16</b>	<b>\$3,822,689.84</b>
<b><u>SPECIAL PROJECTS RESERVE</u></b>		<b>\$250,000.00</b>	<b>\$0.00</b>	<b>\$250,000.00</b>
<b><u>CONTINGENT LIABILITY RESERVE</u></b>		<b>\$300,000.00</b>	<b>\$0.00</b>	<b>\$300,000.00</b>
<b><u>BUILDING RESERVE</u></b>		<b>\$900,000.00</b>	<b>\$0.00</b>	<b>\$900,000.00</b>
<b><u>EQUIPMENT RESERVE</u></b>		<b>\$400,000.00</b>	<b>\$0.00</b>	<b>\$400,000.00</b>
<b><u>GENERAL RESERVE</u></b>		<b>\$3,978,000.00</b>	<b>\$0.00</b>	<b>\$3,978,000.00</b>
	<b>TOTAL RESERVES</b>	<b>\$5,828,000.00</b>	<b>\$0.00</b>	<b>\$5,828,000.00</b>
<b>TOTAL EXPENDITURES AND RESERVES</b>		<b>\$10,148,000.00</b>	<b>\$497,310.16</b>	<b>\$9,650,689.84</b>

## Consolidated Mosquito Abatement District Monthly Expenditures

### FRESNO COUNTY ACCOUNT- BANK OF THE WEST

<b>CASH ON HAND, JUNE 30, 2021</b>	<b>\$6,099,515.55</b>
PROPERTY TAXES WITHHELD BY FRS COUNTY	\$0.00
JULY REVENUE	\$0.00
JULY INTEREST	\$0.00
TAXES - FRESNO COUNTY / KINGS COUNTY	\$0.00
TOTAL REVENUE FOR JULY	<u>\$0.00</u>
<b>SUB-TOTAL</b>	<b>\$6,099,515.55</b>
COUNTY ADMIN COST FOR FY WITHHELD BY COUNTY	\$0.00
MONEY TRANSFERRED TO CHECKING	<u>(\$504,806.21)</u>
<b>CASH ON HAND, JULY 31, 2021</b>	<b>\$5,594,709.34</b>

YEARLY REVENUE THROUGH 07-01-21	\$0.00
JULY REVENUE	<u>\$0.00</u>
YEARLY REVENUE THROUGH 07-31-21	<b>\$0.00</b>

### CMAD CHECKING ACCOUNT - BANK OF THE WEST

<b>CASH ON HAND, JUNE 30, 2021</b>	<b>\$135,000.00</b>
MONEY TRANSFERRED FROM FRS CO ACCT	\$504,806.21
JULY EXPENDITURES	<u>(\$504,806.21)</u>
<b>CASH ON HAND, JULY 31, 2021</b>	<b>\$135,000.00</b>

### SAVINGS ACCOUNT- CITIBANK

<b>CASH ON HAND, JUNE 30, 2021</b>	<b>\$14,112.25</b>
INTEREST EARNED FOR JULY	<u>\$0.60</u>
<b>CASH ON HAND, JULY 31, 2021</b>	<b>\$14,112.85</b>



Print Close

STEVE MULLIGAN - XXXX-XXXX-XXXX-

Statement Balance: \$3,210.98  
 Last Payment Amount: \$1,881.15  
 Minimal Payment Due on 09/02/21: \$48.00  
 Statement/Closing Date: 08/09/2021

*6102-02 989.65 6102-04 104.69*  
*6106-05 241.95*  
*6109-07 1120.79*  
*6109-09 231.84*  
*6109-03 163.29*  
*6101-07 35.00*  
*6106-02 179.30*  
*6102-01 100.00*  
*6108-03 44.47*

ACCOUNT SUMMARY

Previous Balance	\$1,881.15
Payments, Credits, and Adjustments	\$1,881.15
Purchases	\$3,210.98
Cash Advances	\$0.00
Fees	\$0.00
Interest Charges	\$0.00
<b>New Balance</b>	<b>\$3,210.98</b>

QUICK REFERENCE

Minimum Payment	\$48.00
New Balance	\$3,210.98
Payment Due Date	09/02/2021
Business Credit Line	\$50,900.00
Cash Advance Line	\$21,500.00
Available Credit Line	\$47,689.00
Available Cash Advance Line	\$21,500.00

STATEMENT MESSAGES

Great News. Your Quarterly summary is now available online. Please go to [www.citicards.com](http://www.citicards.com) and login to your account online for more details.

Please be sure to pay on time. If you submit your payment by mail, we suggest you mail it no later than 08/26/2021 to allow enough time for regular mail to reach us.

FINANCE CHARGE SUMMARY

	Nominal APR	Periodic Finance Change	Transaction Fee/Interest Change
Purchases (Standard Purch)	21.240%	\$0.00	\$0.00
Cash Advances (Standard Adv)	21.240%	\$0.00	\$0.00
<b>TOTAL Interest Charge</b>	<b>\$0.00</b>		

BUSINESS PAYMENTS, CREDITS, AND ADJUSTMENTS

Post Date	Description	Amount
07/22	ONLINE PAYMENT, THANK YOU	(\$1,881.15)

CARDHOLDER SUMMARY

Cardholder	Account Number (Last 4 digits)	Employee Credit Line	Employee Cash Advance Line	Total Activity Amount
FRED S MULLIGAN	0151	\$15,100	\$0	\$3,166.51

Transaction Date:	Post Date:	Description:	Charged to:	Amount:
08/09	08/09	<i>ATV Helmet</i> AMZN Mkip US*2P98849S0 Amzn.com/bill	Standard	\$46.30 <i>6102-02</i>

	WA		Purch	
08/05	08/05	Amazon.com*2P2UL98G0 Amzn.com/bill WA <i>Graphics card - velcro</i>	Standard Purch	\$85.88 <i>6106-05</i>
08/04	08/04	AMZN Mktp US*2P3SY86H1 Amzn.com/bill WA <i>Alcohol Wipes</i>	Standard Purch	\$18.47 <i>6106-05</i>
08/03	08/03	Amazon.com*2P43H4QB1 Amzn.com/bill WA <i>1/3 gallon coolers</i>	Standard Purch	\$292.43 <i>6109-07</i>
08/03	08/03	SP * QORE PERFORMANCE STERLING VA <i>Cooling Vest</i>	Standard Purch	\$386.89 <i>6109-07</i>
08/03	08/03	Amazon.com*2P27323N2 Amzn.com/bill WA <i>Evaporative Cooling bandanas</i>	Standard Purch	\$369.98 <i>6109-07</i>
08/02	08/02	AMZN Mktp US*2P42S5EH0 Amzn.com/bill WA <i>75th Anniversary decorations</i>	Standard Purch	\$21.11 <i>6109-09</i>
07/31	07/31	CRAIGSLIST.ORG 415-399-5200 CA <i>Vehicle ad</i>	Standard Purch	\$5.00 <i>6109-03</i>
07/30	07/30	CRAIGSLIST.ORG 415-399-5200 CA <i>Vehicle ad</i>	Standard Purch	\$5.00 <i>6109-03</i>
07/30	07/30	CRAIGSLIST.ORG 415-399-5200 CA <i>Vehicle ad</i>	Standard Purch	\$5.00 <i>6109-03</i>
07/30	07/30	CHECKR, INC CHECKR.COM SAN FRANCISCO CA <i>Background checks</i>	Standard Purch	\$35.00 <i>6101-07</i>
07/30	07/30	CRAIGSLIST.ORG 415-399-5200 CA <i>Vehicle ad</i>	Standard Purch	\$5.00 <i>6109-03</i>
07/30	07/30	CRAIGSLIST.ORG 415-399-5200 CA <i>Vehicle ad</i>	Standard Purch	\$5.00 <i>6109-03</i>
07/30	07/30	CRAIGSLIST.ORG 415-399-5200 CA <i>Vehicle ad</i>	Standard Purch	\$5.00 <i>6109-03</i>
07/29	07/29	AMZN Mktp US*2P6JB8E31 Amzn.com/bill WA <i>1/3 gallon coolers</i>	Standard Purch	\$43.36 <i>6109-07</i>
07/28	07/28	Amazon.com*2E5X627N2 Amzn.com/bill WA <i>Cooling Neck bandanas</i>	Standard Purch	\$28.33 <i>6109-07</i>
07/28	07/28	FACEBK 5VTMM53K92 Menlo Park CA <i>Facebook ads</i>	Standard Purch	\$50.00 <i>6109-03</i>
07/27	07/27	AMZN Mktp US*2E3UW2DQ2 Amzn.com/bill WA <i>Fish Program Supplies</i>	Standard Purch	\$104.69 <i>6102-04</i>
07/26	07/26	MSFT * E0700FE8DO 8006427676 WA <i>Microsoft office - monthly</i>	Standard Purch	\$82.50 <i>6106-05</i>
07/22	07/22	AMZN Mktp US*2E9A96RU1 Amzn.com/bill WA <i>75th Anniversary supplies</i>	Standard Purch	\$15.24 <i>6109-09</i>
07/20	07/20	MY M&M 8886966788 NJ <i>75th Anniversary giveaway</i>	Standard Purch	\$195.49 <i>6109-09</i>
07/18	07/18	AMZN Mktp US*2E4HE0LP2 Amzn.com/bill WA <i>Door stoppers</i>	Standard Purch	\$16.34 <i>6106-05</i>

07/17	07/17	FACEBK MJG244PJ92 Menlo Park CA <i>Facebook posts</i>	Standard Purch	\$8.09	<i>6/09-03</i>	
07/16	07/16	SP * KESTRELMETERS.COM 2482708898 PA <i>Weather Meters</i>	Standard Purch	\$869.63	<i>6/02-02</i>	
07/16	07/16	IN *ALLWEBCO, INC. 251-6544124 AL <i>Domain Renewal</i>	Standard Purch	\$25.00	<i>6/09-03</i>	
07/14	07/14	BIG 5 SPORTING GOODS 3 SELMA CA <i>Water Carrier for trucks</i>	Standard Purch	\$73.72	<i>6/02-02</i>	
07/14	07/14	USPS PO 0558560648 PARLIER CA <i>Postage</i>	Standard Purch	\$179.30	<i>6/06-02</i>	
07/14	07/14	FREE CONFERENCE CALL G 877-5531680 CA <i>Conference Call dedicated number</i>	Standard Purch	\$3.95	<i>6/06-05</i>	
07/12	07/12	FACEBK ZP5D74FJ92 Menlo Park CA <i>Facebook ads</i>	Standard Purch	\$50.00	<i>6/09-03</i>	
07/12	07/12	AMZN MKTP US*297VN8S12 AMZN.COM/BILL WA <i>cell phone case &amp; screen protector</i>	Standard Purch	\$34.81	<i>6/06-05</i>	
07/08	07/09	SP * SUMMIT CHEMICAL S BALTIMORE MD <i>Mosquito Dunks</i>	Standard Purch	\$100.00	<i>6/02-01</i>	
STEVE MULLIGAN	2859			\$50,900	\$21,500	\$44.47

Transaction Date:	Post Date:	Description:	Charged to:	Amount:
07/15	07/15	LEGENDSTAPHOUSEGRILL SELMA CA	Standard Purch	\$44.47 <i>6/08-03</i>

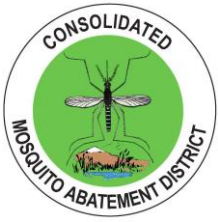

# Consolidated Mosquito Abatement District

13151 E. INDUSTRIAL DR.  
MAIL: P.O. BOX 784  
PARLIER, CALIFORNIA 93648  
(559) 896-1085  
FAX (559) 896-6425  
www.mosquitobuzz.net

## SALE OF SURPLUS PROPERTY: TERMS AND CONDITIONS

**2003 Ford F250 2WD**  
**2005 Ford F150 2WD**  
**2006 Chevrolet Silverado 2WD**  
**2007 Chevrolet Colorado 4WD**  
**2009 Chevrolet Colorado 4WD**  
**2009 Chevrolet Colorado 4WD**

The District Board of Trustees (Board) has declared to be surplus property and is selling, by sealed bid, six (6) pickup trucks. The vehicles are available for inspection during the hours 8am – 3pm at the Consolidated Mosquito Abatement District, 13151 E. Industrial Dr., Parlier, CA. Minimum bid required for each vehicle is as follows:

<u>Item No.</u>		<u>V.I.N.</u>	<u>Minimum Bid</u>
#1	2003 Ford F250 2WD	3FTNF20L33MB24842	\$3,600.00
#2	2005 Ford F150 2WD	1FTRF12W85NC02009	\$4,000.00
#3	2006 Chevrolet Silverado 2WD	3GCEC14V96G225188	\$4,500.00
#4	2007 Chevrolet Colorado 4WD	1GCDT14E978206935	\$4,500.00
#5	2009 Chevrolet Colorado 4WD	1GCDT14E898145466	\$5,000.00
#6	2009 Chevrolet Colorado 4WD	1GCDT14EX98146604	\$5,000.00

The vehicles are to be sold individually on an “as is” basis, without warranty of any kind by the District. The District, as a government agency, is not required to provide and shall not furnish a smog certificate of compliance with the sale of a vehicle. **Please note that the buyer is required to obtain a smog certificate of compliance for vehicle registration.**

Prospective buyers shall submit a sealed bid, to be received by the District **prior** to 3:00 pm on Friday, August 13, 2021 at the District headquarters.

Bids may be hand delivered to the District headquarters at 13151 E. Industrial Dr., Parlier, or mailed to the Consolidated Mosquito Abatement District, PO Box 784, Parlier, CA, 93648, and shall have “**VEHICLE BID**” plainly marked on the outside of the envelope.

The bids will be opened at close of bidding and the Board will consider the bids at the August 16, 2021, Board meeting. The Board reserves the right to reject any or all bids. Only the highest bidder for a vehicle will be notified. If the highest bidder does not complete the transaction, the next highest bidder will be notified, and so on, until the vehicle is sold. If two or more bidders have identical bids, the earliest submitted bid (date of receipt) will be accepted.

The prospective buyer must complete the transaction within three working days of receipt of notification of bid acceptance. The District shall release the vehicle to the buyer upon payment of the entire sum, by valid bank draft or cashier’s check made out to the Consolidated Mosquito Abatement District. The District will also deliver a certificate of ownership transferring title to the buyer. The buyer shall be responsible for any and all sales tax, transfer fees and other fees or costs associated with the transfer.

Community health, comfort and prosperity are promoted by effective, continuous mosquito abatement measures.

# Consolidated Mosquito Abatement District

## Bid Offer Form 2021-02

### Surplus District Vehicles

Item No.	Year	Model	VIN Number	Minimum Bid Price	Submitted Bid Price
#1	2003	Ford F250 2WD	3FTNF20L33MB24842	\$3,600.00	\$_____
#2	2005	Ford F150 2WD	1FTRF12W85NC02009	\$4,000.00	\$_____
#3	2006	Chevrolet Silverado 2WD	3GCEC14V96G225188	\$4,500.00	\$_____
#4	2007	Chevrolet Colorado 4WD	1GCDDT14E978206935	\$4,500.00	\$_____
#5	2009	Chevrolet Colorado 4WD	1GCDDT14E898145466	\$5,000.00	\$_____
#6	2009	Chevrolet Colorado 4WD	1GCDDT14EX98146604	\$5,000.00	\$_____

---

### Bidder Information

Name: \_\_\_\_\_

Address: \_\_\_\_\_

Phone No: \_\_\_\_\_

Email: \_\_\_\_\_

Signature: \_\_\_\_\_





## **Consolidated Mosquito Abatement District**

### **Investment Report**

**Quarter Ending June 30, 2021**

A review of the financial statements indicates there are sufficient funds to meet the expected requirements for the next six months.

The Fresno County Treasury is the primary investment instrument for District funds, including the District's unobligated fund maintained by the Central California Vector Control Joint Powers Agency. A business checking account at Bank of the West is maintained by the District for payment of District payroll and bills. A savings account at CitiBank is maintained by the District. Copies of the most recent financial statements from these institutions are attached.

The foregoing accounts, cash and investments of the Consolidated Mosquito Abatement District are in conformity with the District's Investment Policy.

Respectfully submitted,



Steve Mulligan  
District Manager

Report ID: GLSPF9109  
 Program: GLSPF9109

PeopleSoft  
 MONTHLY GENERAL LEDGER TRIAL BALANCE  
 Fiscal Year 2021  
 Through Period 12

Page No. 1  
 Run Date 07/30/2021  
 Run Time 00:08:10

Fund:	4580	Beginning Balance		Year-to-Date		Transaction		Current Balances	
Consolidated Mosquito Abtmt		Debit Accts	Credit Accts	Debits	Credits	Debits	Credits	Debits Accts	Credit Accts
Subclass: 10000									
General Subclass									
0110 Cash In Treasury		5,891,076.22	0.00	365,783.32	0.00	6,256,859.54	0.00		
0315 Interest Receivable		28,363.81	0.00	12,940.09	0.00	41,303.90	0.00		
1435 Due To Other Governmental		0.00	7,898,119.01	0.00	2,066.01	0.00	7,900,185.02	0.00	0.00
1450 Deposits Held For Others-T		0.00	1,668.49	0.00	0.00	0.00	1,668.49	0.00	0.00
1480 Fiduciary Closing		0.00	17,955,256.01	0.00	0.00	0.00	17,945,869.28	0.00	17,945,869.28
2230 Fund Balance - Unassigned		0.00	-19,935,603.48	9,386.73	0.00	0.00	-23,756,033.41	0.00	-23,756,033.41
3005 RDA ABX1 26 Property Tax		0.00	0.00	3,820,429.93	0.00	0.00	122,675.89	0.00	122,675.89
3006 Redeem Tax Increm Reimb		0.00	0.00	0.00	122,675.89	0.00	62,274.87	0.00	62,274.87
3007 Suppl-Prior Unsecured		0.00	0.00	0.00	62,274.87	0.00	182.79	0.00	182.79
3008 Suppl-Prior Secured		0.00	0.00	0.00	182.79	0.00	1,728.98	0.00	1,728.98
3009 Suppl-Current Unsecured		0.00	0.00	0.00	1,728.98	0.00	853.23	0.00	853.23
3010 Property Taxes-Current Sec		0.00	0.00	0.00	853.23	0.00	3,599,695.96	0.00	3,599,695.96
3011 Suppl-Current Secured		0.00	0.00	0.00	3,599,695.96	0.00	76,120.92	0.00	76,120.92
3013 Supplemental-Curr Unsec Pr		0.00	0.00	0.00	76,120.92	0.00	575.92	0.00	575.92
3015 Property Taxes-Curr Unsec		0.00	0.00	0.00	575.92	0.00	173,668.51	0.00	173,668.51
3017 Property Taxes-Curr Unsec		0.00	0.00	0.00	173,668.51	0.00	32,464.73	0.00	32,464.73
3020 Property Taxes-Prior Secur		0.00	0.00	0.00	32,464.73	0.00	714.14	0.00	714.14
3025 Property Taxes-Prior Unsec		0.00	0.00	0.00	714.14	0.00	1,458.14	0.00	1,458.14
3030 Penalties & Costs-Debtinq T		0.00	0.00	0.00	1,458.14	0.00	709.01	0.00	709.01
3046 Joint County Funds		0.00	0.00	0.00	709.01	0.00	8,997.50	0.00	8,997.50
3380 Interest		0.00	0.00	0.00	8,997.50	0.00	89,724.81	0.00	89,724.81
3565 State-I/L Homeowners Prop		0.00	0.00	0.00	89,724.81	0.00	29,544.01	0.00	29,544.01
4369 Federal In Lieu - Housing		0.00	0.00	0.00	29,544.01	0.00	336.42	0.00	336.42
5804 ABX126 Other Revenue		0.00	0.00	0.00	336.42	0.00	6,176.51	0.00	6,176.51
SUB CLASS TOTAL		5,919,440.03	5,919,440.03	4,209,254.21	4,209,254.21	6,298,163.44	6,298,163.44		

End of Report



**BANK OF THE WEST**  
**BNP PARIBAS**

P.O. Box 2830, Omaha, NE 68103-2830

## Account Statement

June 1, 2021 - June 30, 2021

Page 1 of 18

### At your service



bankofthewest.com



1-800-488-2265



1-800-659-5495 TTY

CONSOLIDATED MOSQUITO DISTRICT  
 P O BOX 784  
 PARLIER CA 93648-0784

Thank you for banking with Bank of the West. We appreciate your business and look forward to continuing to serve your banking needs.

Remember to confirm your email during your next branch visit or call our Contact Center at 800-488-2265. Our emails keep you educated about our services, products and more.

## REGULAR BUSINESS CHECKING

CONSOLIDATED MOSQUITO DISTRICT

### ACCOUNT SUMMARY

<b>Beginning Balance</b>	<b>\$176,236.04</b>
0 Credits	0.00
3 Deposits	257,827.48
13 Withdrawals	-78,363.68
132 Checks	-197,816.60
<b>Ending Balance</b>	<b>\$157,883.24</b>

### EARNINGS SUMMARY

Interest this statement period	\$0.00
Interest credited year-to-date	\$0.00
Annual percentage yield earned	0.00%
Average monthly balance	\$182,279.32

### For your protection:

Examine this statement promptly. Any discrepancy must be reported within 30 days. Consumer customers: A discrepancy regarding an electronic payment or line of credit must be reported within 60 days.



CENTRAL CALIFORNIA VECTOR CONTROL JOINT POWERS AGENCY									
<u>UNOBLIGATED FUNDS</u>									
							4th Quarter (Ending 6/30/2021)		
		BEG. BAL.	ACTIV.	END. BAL.			(End Bal.)		
CONSOLIDATED-10		\$127,852.18	\$909.39	\$128,761.57			FUND SHARE		
							6.845536759		
FWMAD-19		\$526,544.24	\$3,745.23	\$530,289.47			28.1925427		
KINGS-23		\$212,032.26	\$1,508.15	\$213,540.41			11.35275631		
MADERA-27		\$224,231.42	\$1,594.92	\$225,826.34			12.0059309		
MERCED-29		\$90,811.39	\$645.93	\$91,457.32			4.862277199		
West Side - 47		\$685,402.94	\$4,875.17	\$690,278.11			36.69824914		
OPER. - 60		\$797.62	\$5.68	\$803.30			0.042706995		
TOTAL		\$1,867,672.05	\$13,284.47	\$1,880,956.52			100.00		
<u>DETAIL SUMMARY OF ACTIVITY (operational fund &amp; life funds)</u>									
	CMAD	FWMAD	KINGS	MADERA	MERCED	WEST SIDE	OP FUND		
\$	909.39	\$ 3,745.23	\$ 1,508.15	\$ 1,594.92	\$ 645.93	\$ 4,875.17	\$ 5.67	Interest	
							\$ -	Dues	
							\$ -	Audit	
							\$ 0.01		
	\$909.39	\$3,745.23	\$1,508.15	\$1,594.92	\$645.93	\$4,875.17	\$5.68		



Citibank CBO Services 987  
 P.O. Box 6201  
 Sioux Falls, SD 57117-6201

00031867 BB CCC 211 JSW3#5NC AM1 U79 0

CitiBusiness®

001/R1/04F013

000  
 CITIBANK, N. A.  
**Account**  
**Statement Period**  
**Jul 1 - Jul 31, 2021**  
**Relationship Manager**  
 US SERVICE CENTER  
 1-877-528-0990

00032582  
 N107

CONSOLIDATED MOSQUITO  
 ABATE DISTRICT  
 PO BOX 784  
 PARLIER CA 93648



Page 1 of 2

**CitiBusiness® ACCOUNT AS OF JULY 31, 2021**

**Relationship Summary:**

Checking	*****
Savings	<b>\$14,112.85</b>
Checking Plus	*****

**SERVICE CHARGE SUMMARY FROM JUNE 1, 2021 THRU JUNE 30, 2021**

Type of Charge	No./Units	Price/Unit	Amount
<b>CITIBUSINESS IMMA #</b>			
Average Daily Collected Balance			\$14,111.68
<b>Total Charges for Services</b>			<b>\$0.00</b>
<b>Net Service Charge</b>			<b>\$0.00</b>

**SAVINGS ACTIVITY**

**CitiBusiness IMMA**

		<b>Beginning Balance:</b>	\$14,112.25
		<b>Ending Balance:</b>	\$14,112.85
Date	Description	Debits	Credits
07/30	INTEREST EARNED		0.60
			14,112.85

Interest earned year to date \$4.10

**Your CitiBusiness IMMA Account Rates**

For Balances of	\$0	\$25,000	\$50,000	\$100,000	\$500,000	\$1,000,000	\$10,000,000
to	to	to	to	to	to	to	
\$24,999	\$49,999	\$99,999	\$499,999	\$999,999	\$9,999,999	and over	
7/01 - 7/31	0.050%	0.050%	0.050%	0.050%	0.050%	0.050%	0.050%

32582

32582

EOLR6401L 1076 5034 CF0033 07 21.0731 PAGE 00001 OF 00001

**Consolidated Mosquito Abatement District  
 Reimbursement Disclosure Report - Fiscal Year 2020 - 2021**

There were no reimbursements to disclose in Fiscal Year 2020 - 2021

<b>Date Paid</b>	<b>Name</b>	<b>Dates Incurred</b>	<b>Lodging</b>	<b>Meals</b>	<b>Transportation Air / Mileage</b>	<b>Other</b>	<b>Description</b>

## **AGENDA ITEM 10: PURCHASE OF ICE MACHINE**

### **Background:**

District staff who work under field conditions, whether control operations or surveillance, are subject high temperatures. With safety protocols, the District is required to provide heat illness prevention training and provide for breaks from heat, shade and availability of hydration. Employees are encouraged to take frequent breaks from heat, have vehicles with air conditioning and are provided with drinking water containers. To provide for cold water at the headquarters facility, ice is provided with the use of a commercial grade ice machine. Currently, we do not have an ice machine at our Clovis Depot and other lesser arrangements are made such as purchase of ice.

A better arrangement for providing ice and cold drinking water for employees at Clovis, and to comply with heat illness prevention, would be the purchase and installation of a commercial ice machine at Clovis.

Quotations for the purchase of commercial grade ice machines were obtained from:

J&E Restaurant Supply Inc. (224 Van Ness Ave., Fresno)

Ice-O-Matic ICEU220 \$2,350 plus \$79 filter

CRESCO RESCO Restaurant Equipment & Supply (2018 S. Van Ness Ave., Fresno)

Manitowoc NEO UYF-0190A \$2,466 plus \$565 filter

Both ice machines have similar features. J&E sells both and recommends the Ice-O-Matic.

### **Action requested:**

The Board approve the purchase of the Ice-O-Matic ICEU220 from J&E Restaurant Supply Inc.

90 lbs



# NEO® 140/190 Undercounter Ice Machines

## Models

- URF-0140A
- UDF-0140A

- UYF-0140A

- UDF-0190A

- UYF-0190A - 2,464.00

Filter - 565.00

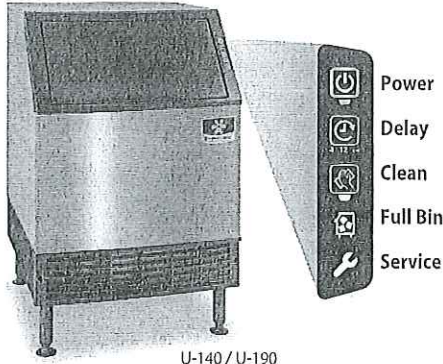

U-140 / U-190

- Ranging from 137 lbs. (62 kg) to 198 lbs. (90 kg) daily ice production
- Only 26" (66.04 cm) wide, 28.50" (72.4 cm) deep, and 38.50" (97.8 cm) high on 6" (15.24 cm) legs
- Cabinet volume 3.037 ft<sup>3</sup> (0.086 m<sup>3</sup>)
- 90 lb. (40.0 Kg) ice storage capacity\*
- \* Application capacity based on: 90% volume x 33lbs/ft<sup>3</sup> average density of ice.

NEO undercounter ice machines are designed to provide ice right where you need it - within reach. Improvements in **Performance, Intelligence** and **Convenience** make your ice machine easy to own and less expensive to operate.

**Performance** - NEO produces more ice than ever before while using less water and energy. The storage bin provides industry leading capacity.

**Intelligence** - NEO provides feedback with full bin and service indicators. Delay function allows you to pause your machine for slow periods or days when you're closed.

**Convenience** - NEO offers a forward-sliding storage bin for easy access to refrigeration components without having to move the entire ice machine. Smooth, sealed food-zone with removable water trough, distribution tube, and damper door for faster cleaning. AlphaSan added to key internal components.

Available **LuminIce® Virus and Bacteria Inhibitor** controls viruses, bacteria, mold and yeast within the food zone to keep the machine clean longer.

## Specifications

**BTU Per Hour:**  
 U-140: 2,150 (average)  
 2,600 (peak)  
 U-190: 2,150 (average)  
 2,600 (peak)

**Compressor:**  
 Nominal rating: .42 HP

**Refrigerant:**  
 R-404A

**Operating Limits:**

- Ambient Temperature Range: 40° to 110°F (4.4° to 43.3°C)
- Water Temperature Range: 45° to 90°F (4.4° to 32.2°C)
- Water Pressure Ice Maker Water In: Min. 20 psi (137.9 kPa) Max. 80 psi (551.1 kPa)



## Ice Machine Electric

115/60/1. (208-230/60/1 and 230/50/1 available.) 115/60/1 ice machines are factory pre-wired with a 6' (180 cm) power cord and NEMA 5-15P-plug configuration. 208-230/60/1 ice machines are factory pre-wired with a 6' (180 cm) power cord only, no plug is supplied.

**Total Amps:**  
 U-140: 115/60/1; Air-cooled: 5 amps  
 208-230/60/1: Air-cooled: 2.5 amps  
 U-190: 115/60/1: Air-cooled: 6 amps  
 208-230/60/1: Air-cooled: 3 amps

**Maximum fuse size:**  
 Air-cooled: 15 amps  
 HACR-type circuit breakers can be used in place of fuses.

## Ice Shape



**Half Dice**  
 3/8" x 1 1/8" x 7/8"  
 (.95 x 2.86 x 2.22 cm)



**Dice**  
 7/8" x 7/8" x 7/8"  
 (2.22 x 2.22 x 2.22 cm)



**Regular**  
 1 1/8" x 1 1/8" x 7/8"  
 (2.86 x 2.86 x 2.22 cm)



NEO® 140/190 Undercounter Ice Machines





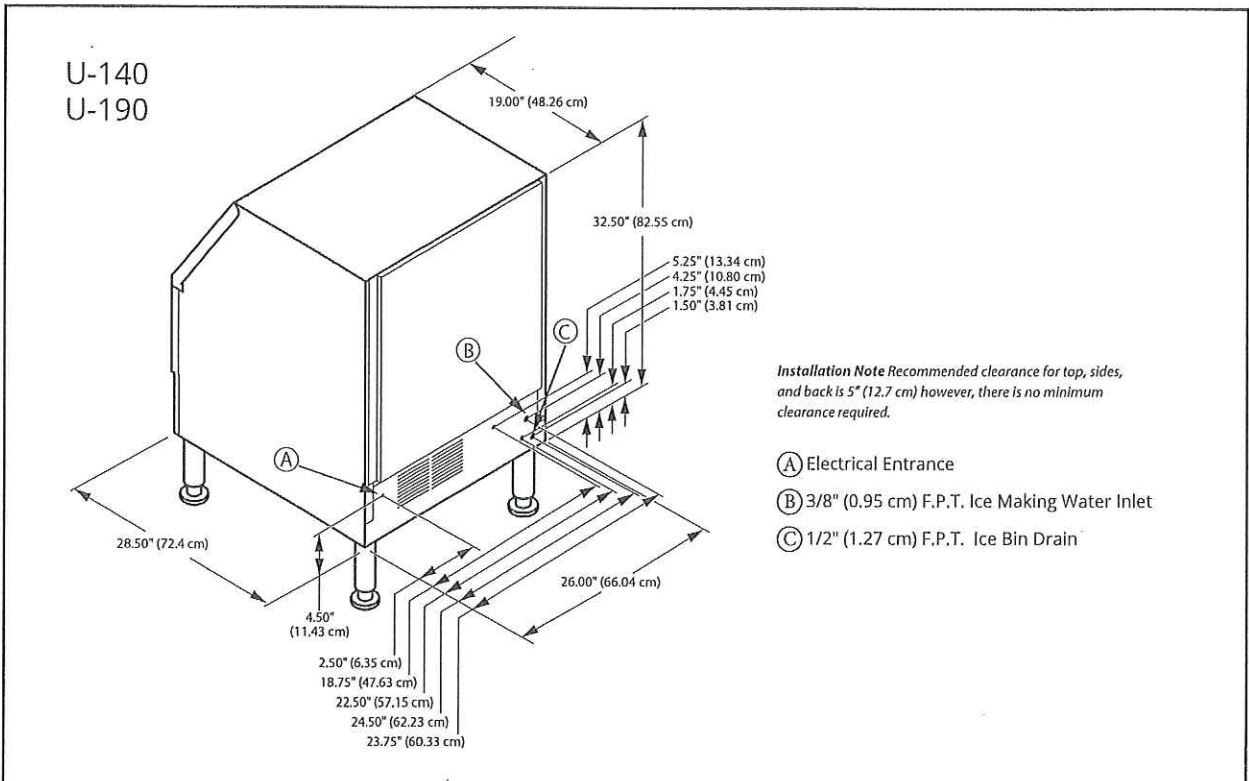

*Installation Note Recommended clearance for top, sides, and back is 5" (12.7 cm) however, there is no minimum clearance required.*

- Ⓐ Electrical Entrance
- Ⓑ 3/8" (0.95 cm) F.P.T. Ice Making Water Inlet
- Ⓒ 1/2" (1.27 cm) F.P.T. Ice Bin Drain

### Specifications

Model	Ice Shape	Ice Production 24 Hours				Power kWh/100 lbs. @ 90°/70°F 32°/21°C	Potable water usage gal/100 lbs. ice @90/70°F
		70°Air/50°F Water 21°Air/10°C Water		90°Air/70°F Water 32°Air/21°C Water			
URF-0140A	regular	127 lbs	58 kg	95 lbs	43 kg	9.6	16.7
UDF-0140A	dice	135 lbs	61 kg	95 lbs	43 kg	9.8	16.7
UYF-0140A	half-dice	137 lbs	62 kg	100 lbs	45 kg	9.2	16.7
UDF-0190A	dice	198 lbs	90 kg	140 lbs	64 kg	8.4	23.9
UYF-0190A	half-dice	193 lbs	88 kg	140 lbs	64 kg	8.3	21.6

Standard 6" / 15.24 cm adjustable flange foot - gray painted legs included.  
Standard plastic NEO ice scoop included.

<p><b>Air Flow</b></p> <p>Air in right, air out left, no side vents. Great for installation under countertops and next to other equipment.</p>	<p><b>Removable Bin</b></p>	<p><b>Air Filter</b></p> <p>Simple, tool-free removal for quick access during routine cleaning and maintenance.</p>
--	-----------------------------	---

Welbilt reserves the right to make changes to the design or specifications without prior notice. ©2018 Manitowoc



# ICEU220/225/226 - SELF CONTAINED CUBE ICE MAKER

90 lbs Full

## Ice-O-Matic

Ice. Pure and Simple



ICEU220

### Features

- Space-saving 24" (623 mm) wide undercounter design.
- Produces up to 251 lbs (114 kg) of ice per day.
- Harvest Assist provides consistent ice production for the life of the ice maker while reducing energy consumption and increasing capacity.
- Pure Ice® exclusively by Ice-O-Matic. Built-in antimicrobial protection for the life of the ice maker inhibits bacteria growth on ice maker surfaces. Ice-O-Matic's optional water filtration system provides protection against unpleasant tastes, odors and scale formation.
- Durable, electroless nickel plating on all evaporator plates ensures reliability.
- Longest warranty in the industry. Purchase an Ice-O-Matic water filter with your cube ice maker, replace the filter every six months, and the evaporator warranty is extended to 7 years parts and labor (available in the U.S. and Canada only).
- Constructed from corrosion-resistant stainless steel and fingerprint-proof plastic.

ICEU220/225/226 SELF CONTAINED CUBE ICE MAKER

### Options & Accessories

Ice Machine Model	WATER FILTERS		
	Manifold		Inline
	System	Replacement	System
ICEU220			
ICEU225	IFQ1	IOMQ (I)	IFI4C / IFI8C
ICEU226			

### Ice Maker Warranty

Every Ice-O-Matic ice maker is backed by a warranty that provides both parts and labor coverage.

- Three years **Parts and Labor**.
- Five years **Parts** coverage on the evaporator and compressor.
- Seven years **Parts and Labor** on the evaporator when you purchase an Ice-O-Matic water filter with your cube ice maker and replace the filter every six months (available in the U.S. and Canada only).

### Ice Form



#### CUBE

CUBE DIMENSIONS	
W x D x H (in.)	7/8 x 7/8 x 7/8
W x D x H (mm)	22 x 22 x 22
ICE PURE DIMENSIONS	
W x D x H (in.)	3/8 x 7/8 x 7/8
W x D x H (mm)	10 x 22 x 22

### Space-Saving Solutions

- Front air discharge design for compact spaces.
- Low profile top saves counter space.
- Stores up to 70 lbs (32 kg) of ice.
- Easy front access to ice.
- Available with an air-cooled or water-cooled condenser.

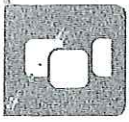

# ICEU220/225/226 - SELF CONTAINED CUBE ICE MAKER

# Ice-O-Matic®

Ice. Pure and Simple

## Air and Water Cooled

- A. Ice maker water in, 3/8" FPT.
- B. Bin and ice maker drain, 3/4" FPT.
- C. Hole for electrical connections, 7/8" (Cord on 115V).
- D. Condenser water in, 3/8" FPT (water cooled units only).
- E. Condenser water out, 1/2" FPT (water cooled units only).

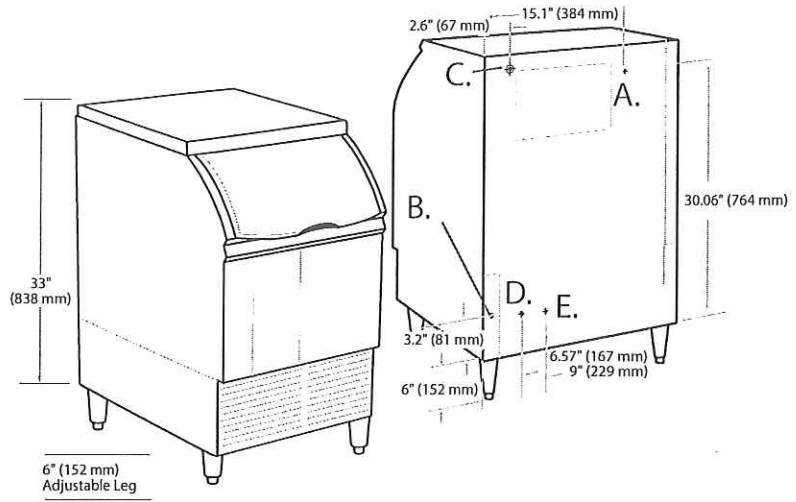

Front & Rear View

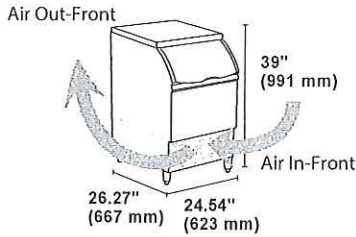

ICEU220/225/226 SELF CONTAINED CUBE ICE MAKER

## Operating Requirements

	MINIMUM	MAXIMUM	
		60 Hz	50 Hz
Ambient Temp. Range Air	50°F (10°C)	100°F (38°C)	110°F (43°C)
Water Temp.	40°F (4.4°C)		
Water Pressure	20 PSIG (1.4 BAR)	60 PSIG (4.1 BAR)	

## Dimensions

ALL MODELS	
W x D x H (in.)	24.54 x 26.27 x 39
W x D x H (mm)	623 x 667 x 991

## Specifications

Model Number	Cooling Unit	ICE MAKING CAPACITY (lb/day)		WATER CONSUMPTION (gal/day)		Energy Efficiency Ratio (EER)	Voltage (V)	Frequency (Hz)	Min. Circuit Ampacity (MCA)	Circuit Breaker Size (A)	Shipping Weight (lb)
		20°F (7°C)	39°F (4°C)	20°F (7°C)	39°F (4°C)						
ICEU220A*	Air	238 (108)	175 (79)	25.0	-	8.80	115/60/1		11.6	15	4,609
ICEU220W*	Water	251 (114)	193 (88)	37.1	175	6.60					
ICEU225A	Air	211 (96)	143 (65)	32.7	-	8.80	220-240/50/1		4.9	16	3,774
ICEU225W	Water	210 (95)	174 (79)	36.6	156	6.30					
ICEU226A*	Air	241 (109)	168 (76)	25.0	-	9.20	208-230/60/1		6.0	15	4,321
ICEU226W	Water	232 (105)	174 (79)	36.6	179	6.59					

\*\*BTUH is calculated 0°F Evaporator, 100°F Condensing, and 33 PSIG.

### NOTES:

- Number of Wires: 3 (including ground)
- Approx. Shipping Weight lbs (kg): ICEU220A 160 (73) · ICEU220W 160 (73) · ICEU225A 160 (73) · ICEU225W 160 (73) · ICEU226A 160 (73) · ICEU226W 160 (73)
- Refrigerant Type: R404A
- \*Cordset included with 115V units.

\*ENERGY STAR qualified machine. Please see our website [www.iceomatic.com](http://www.iceomatic.com) for the latest list of ENERGY STAR qualified machines and available rebates

224 Van Ness Ave  
Fresno, CA 93721-3121  
559-268-5600  
Fax 559-268-0858

Date: 08/10/21

Page: 1

Sold To: CONSOLIDATED MOSQUITO ABATEMEN  
13151 EAST INDUSTRIAL DRIVE  
PARLIER, CA 93648

Customer No: 56907  
Phone No: 217-7906

Ship To: 13151 EAST INDUSTRIAL DRIVE  
PARLIER, CA 93648

Cust. Order #:

Salesperson: #83 - Mindy

Product Code	Item Description	Qty	Unit Price	Amount
ICEU220HA	ICE MACHINE 238 LBS UNDERCOUN	1	2350.00	2350.00*
IOMWFRC	FILTER ICE MACHINE QUICK DIS	1	79.00	79.00*

Sub-Total: 2429.00

:

Shipping: 0.00

Tax [ 8.35]: 202.82 \*

Total: 2631.82

Credit Terms are 30 days from date  
of invoice. No Refunds. \$25 on  
all returned checks

Amount Paid: 0.00

Amount Due: 0.00

Change: 0.00



Don Merritt and Ted Raley at the Front Street office (cir. 1950)

# CMAD Program Report



**August 2021 Board Meeting**

**Steve Mulligan  
District Manager**

**Jovana Benavides,**  
*Associate Biologist*  
**Devon Cornel,**  
*Area Supervisor*  
**Karan Cox,**  
*Office Administrator*  
**B. Deegan,**  
*Vector Biologist*  
**Amy Garcia,**  
*Data Management Associate*  
**Derek Hill,**  
*Urban Program Specialist*  
**Jodi Holeman,**  
*Superintendent of Operations*  
**Chris Monis,**  
*Area Supervisor*  
**Jose Moreno,**  
*Mechanic*  
**Katherine Ramirez,**  
*Science Education Coordinator*  
**Conner Schaak,**  
*GIS Coordinator*  
**Gha Vang,**  
*Area Supervisor*



# Table of Contents

3

General Operations

6

Surveillance

10

Science Education

# GENERAL OPERATIONS

## JULY SERVICE REQUESTS

### Service Requests: 148

Fish	11
Mosquito	120
Swimming Pools	15
Traps	1

### Service Requests by City

Caruthers	1
Clovis	57
Del Rey	0
Fowler	4
Fresno	49
Friant	0
Kingsburg	7
Laton	1
Orange Cove	0
Parlier	1
Reedley	6
Riverdale	3
Sanger	17
Selma	2

### Appointments (by depot): 157

Clovis	110
Reedley	31
Sanger	4
Selma	0
Westside	12

### July Service Requests 2016-2021

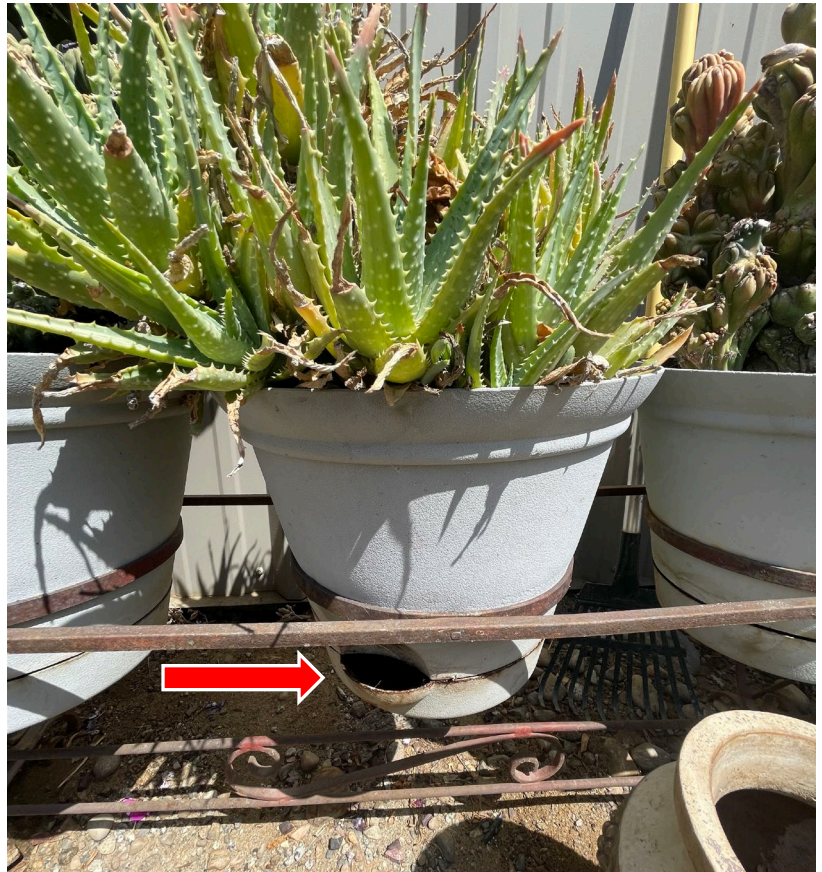
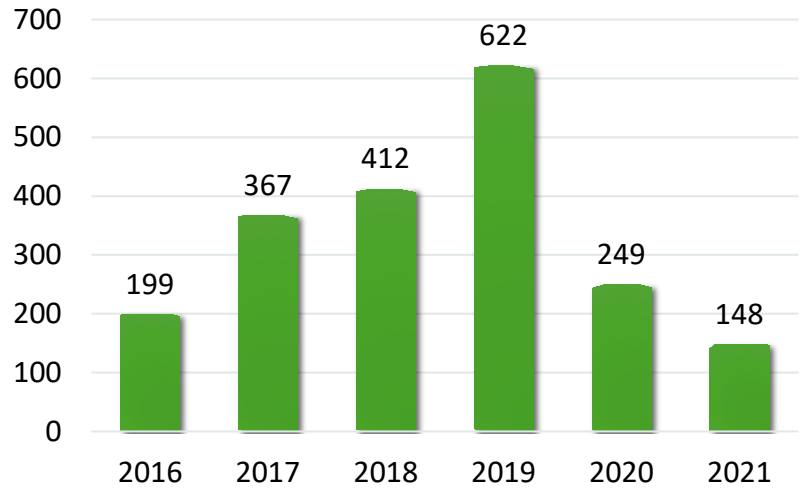

Pot with attached water reservoir raising *Aedes aegypti*



Over irrigated corn producing *Culex* mosquitoes

## July 2021 Field Activity

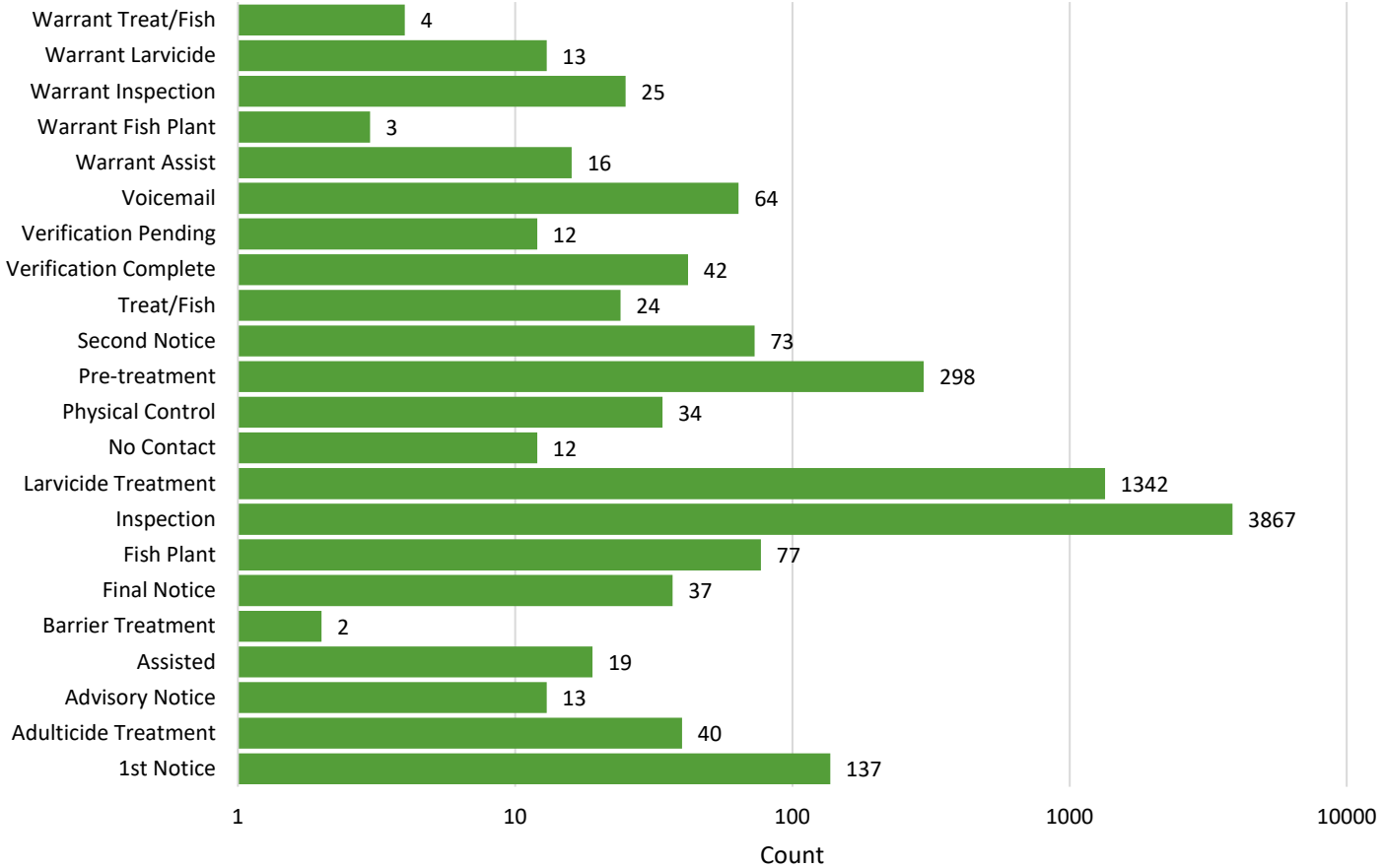



# GENERAL OPERATIONS

## Mosquito Control Applications: 7,596

### Acres Treated

- Larvicide applications: 1250.76 acres
- Mosquito fish plants: 5.2 acres
- Adulticide applications: 2,575.07 acres

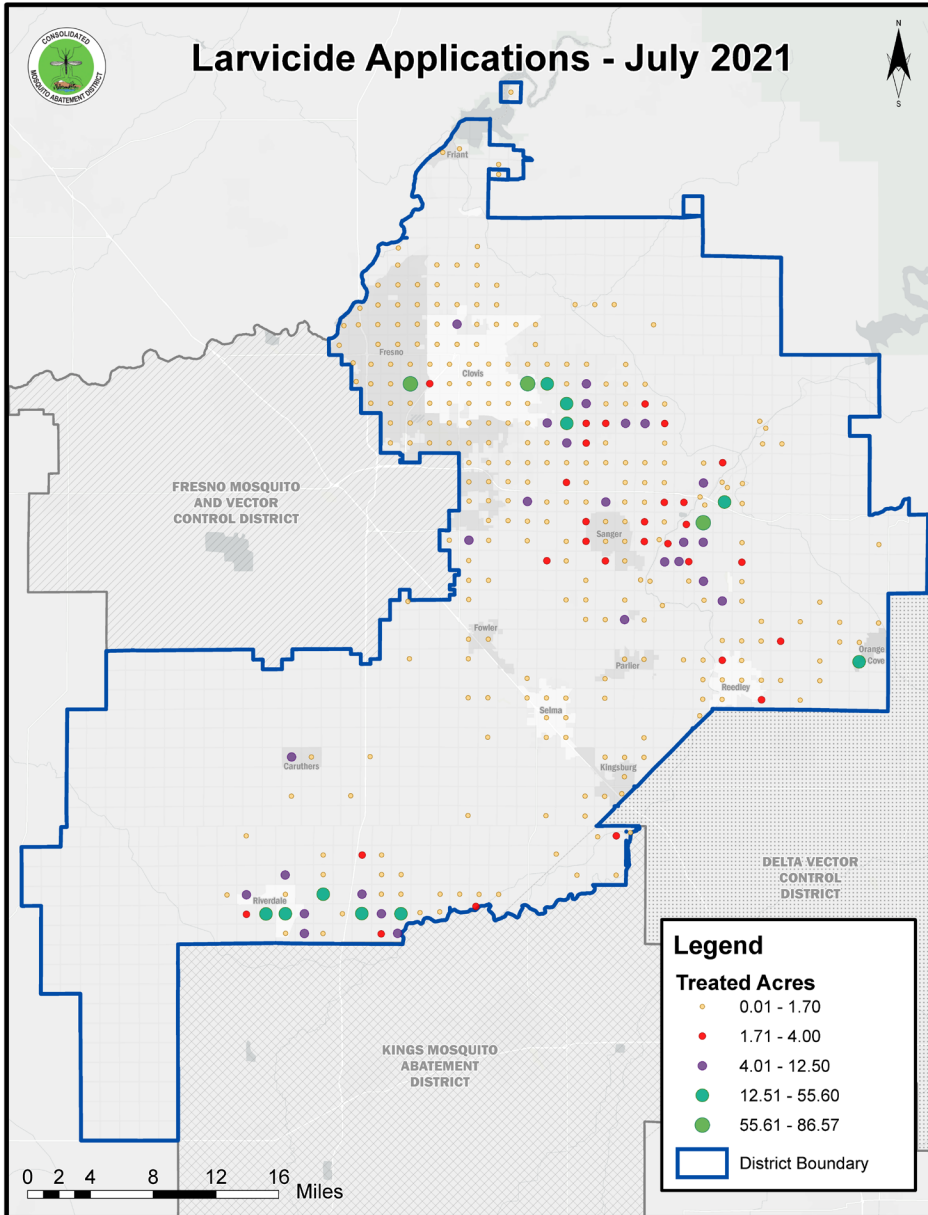

Product	Applications
Altosid WSP	1483
Altosid XR Briquet	13
Altosid XRG	12
Aqua-Kontrol 30-30	8
BVA-2	800
Cocobear MLO	184
DeltaGard*	32
Fish	108
FourStar Bti Briquet	45
FourStar CRG	18
FourStar CRG	72
Mosquito Dunks	36
Natular 2EC	1
Natular G30	422
Natular G30 WSP	3887
Sumilarv	17
Sumilarv WSP	261
Suspend SC*	3
VectoBac 12AS	77
VectoBac GR	64
VectoLex FG	72
VectoLex WDG	26

Map does not include adulticide, catch basin or subsurface enclosure treatments

\*Adulticide products

## MOSQUITO AND DISEASE SURVEILLANCE

**Mosquitoes: 262 mosquito pools\* were submitted for disease testing. Sixty-three pools tested positive for WNV and one pool tested positive for SLEV.**

**Total number of mosquitoes collected and processed by the lab in July: 49,269**

**Total number of trap nights conducted by surveillance staff in July: 908**

**Human Cases: Fresno County reported one human WNV case in July**

### 2021 WEST NILE VIRUS ACTIVITY IN CALIFORNIA

LAST UPDATED: AUG 06, 2021 4:52PM PST

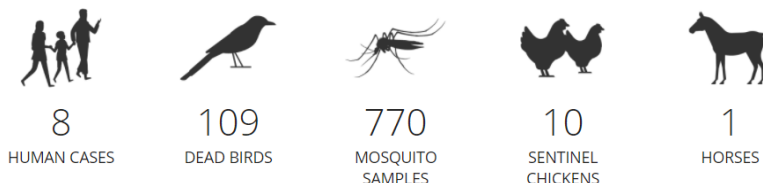

### July Mosquito Collections

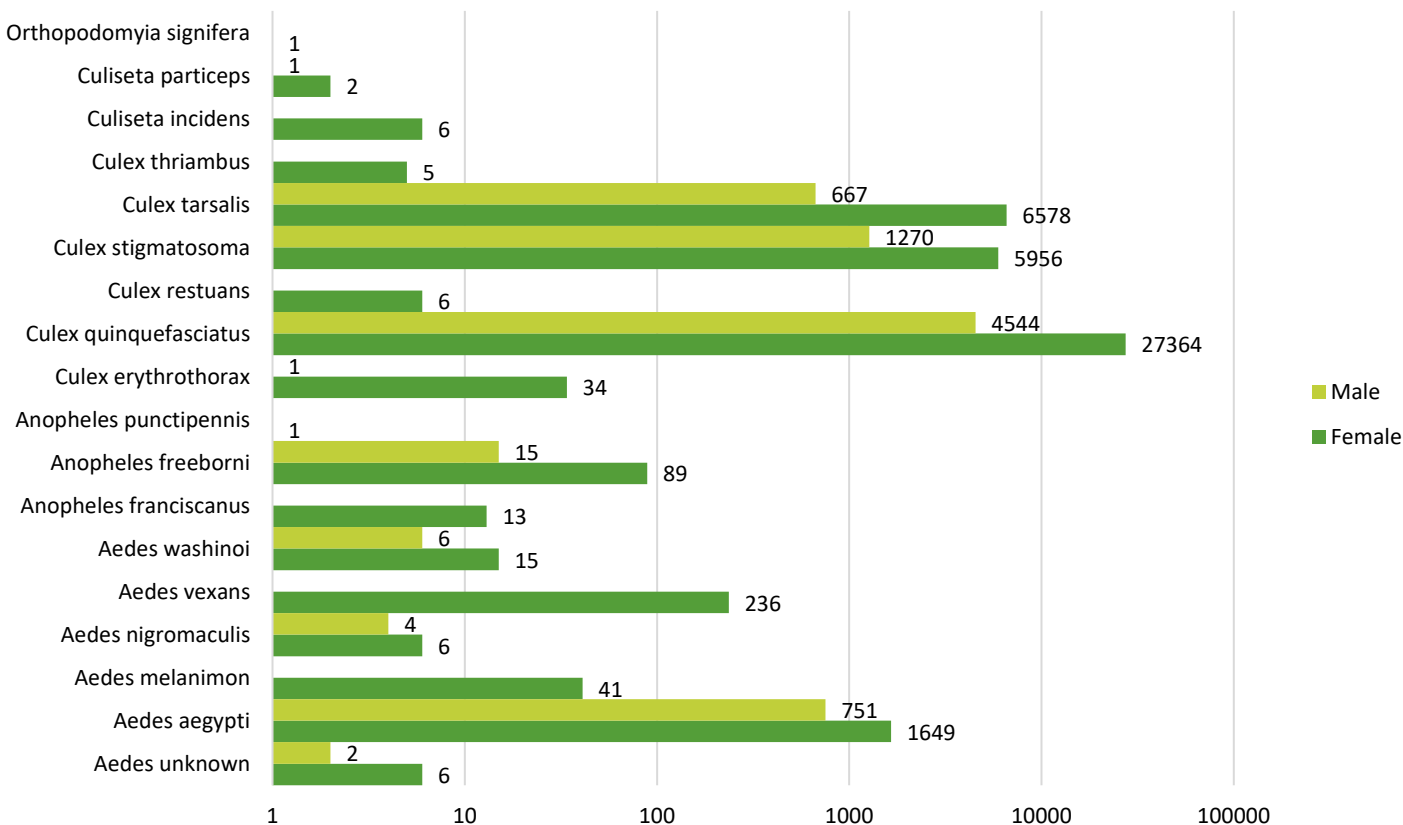

\* Mosquito pools consist of 12-50 adult female mosquitoes tested by the Davis Arbovirus Research and Training Laboratory

## *Orthopodomyia signifera*

In the past 20 years this mosquito has only been collected on 11 separate trap nights. The collection prior to this July 2021 find was in August 2013 from a CO2 baited EVS trap identified by former Surveillance Assistant, Victor Maggi. Although this species is not medically important it's always a treat to collect this rare species.

In a *Vector of the Month* technical report written by retired District Entomologist, Charlie Smith wrote the following:

Among the treehole species of mosquitoes which inhabit California, *Orthopodomyia signifera* is the most unique. Whereas the more familiar Western treehole mosquito, *Aedes sierrensis*, is small and somewhat spotted-looking in the adult stage, *O. signifera* is similar in size to most mosquitoes and looks unlike any other species found in California. Its unique features include thin silvery lines of scales on the dorsal (top) side of the thorax and a speckling of broad white scales on the wings. These scales contrast with associated dark scales to make this mosquito highly attractive in appearance.

Distribution of *O. signifera* in California appears to be spotty and at lower elevations. Like *A. sierrensis*, eggs are laid singly above the water level on the insides of treeholes. Hatching occurs within a few days after rising water reaches the eggs. Whereas *A. sierrensis* can inhabit many species of trees holding temporary winter water, *O. signifera* is normally restricted to treeholes which contain water year-round. Larvae can be found throughout the year in such sources as oaks, cottonwoods, and willows. This species generally overwinters in the egg or larval stage. Adults tend to be long-lived with females preferring the blood of small birds.



# SURVEILLANCE

## MOSQUITO COLLECTION DATA

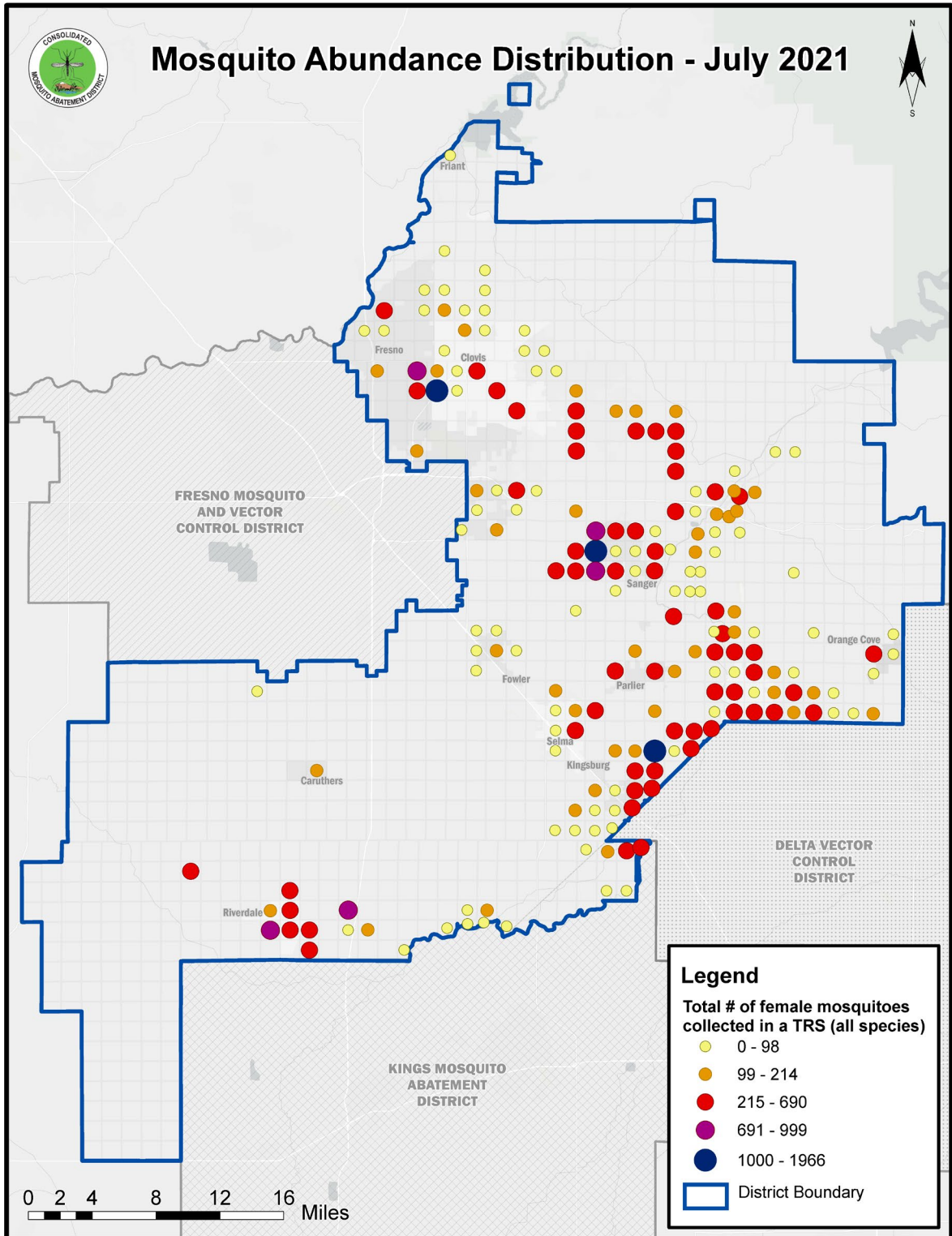

# SURVEILLANCE

## MOSQUITO AND DISEASE SURVEILLANCE



Birds: Nine birds were reported to the California Department of Public Health West Nile virus dead bird hotline within the District. Follow up surveillance was conducted at one location.

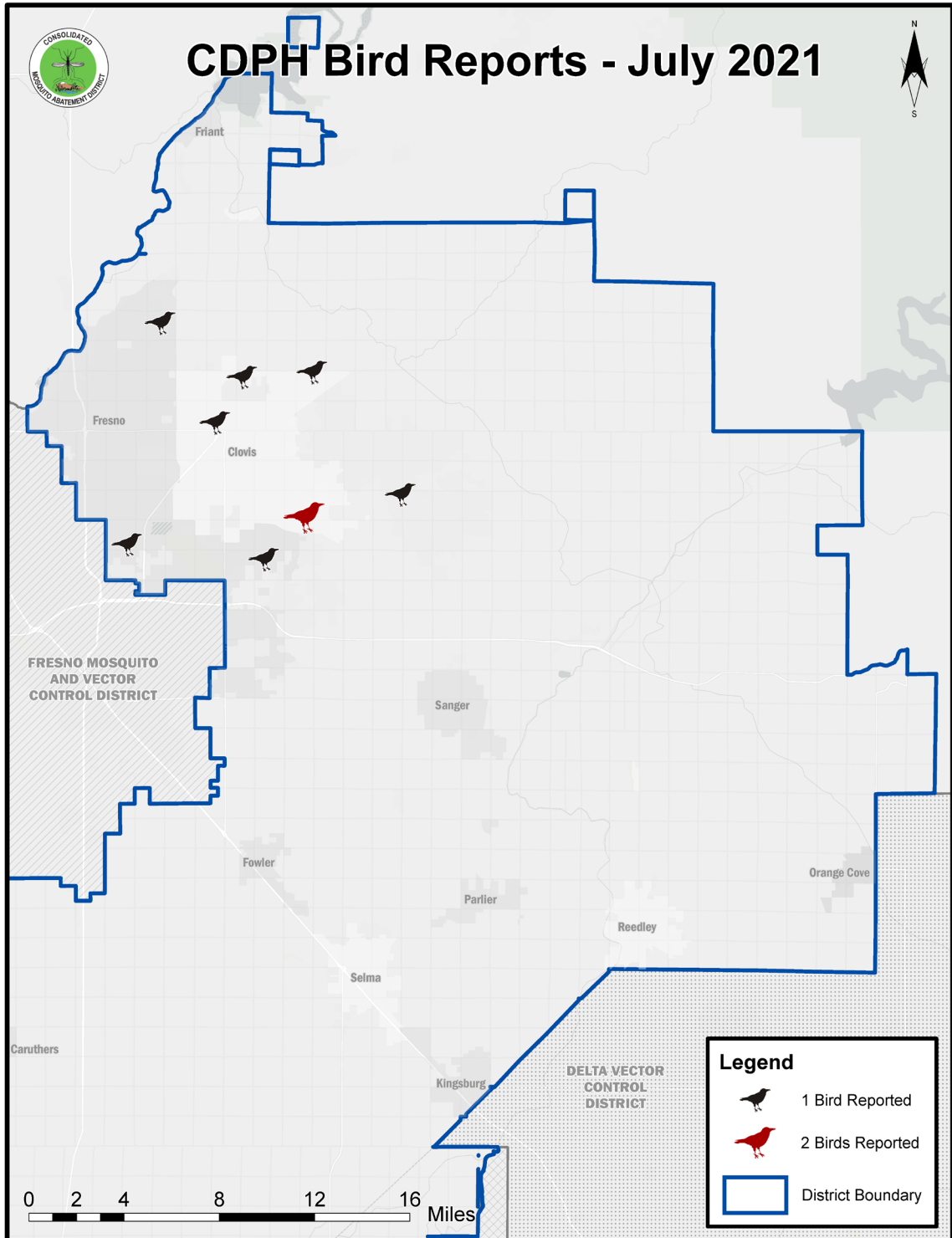

## Community Partners

During July, community partners included three apartment complexes: Clovis (1), and Kingsburg (2); one retirement home in Selma; the Clovis Chamber of Commerce; and five mobile home parks: Selma (1), Reedley (1), and Clovis (3). The only new community partner was an apartment complex in Clovis.

## Community Presentations

On July 13th Science Education Coordinator Katherine Ramirez gave a 15-minute presentation to the Fresno County Communicable Disease Investigation (CDI) Unit, providing an update on disease response and mosquito abatement responsibilities. District Managers Steve Mulligan and Conlin Reis (Fresno Westside MAD) were also in attendance. Twenty-three people participated in the meeting providing the opportunity for MAD representatives to respond to numerous questions from CDI staff on mosquito control and disease response.

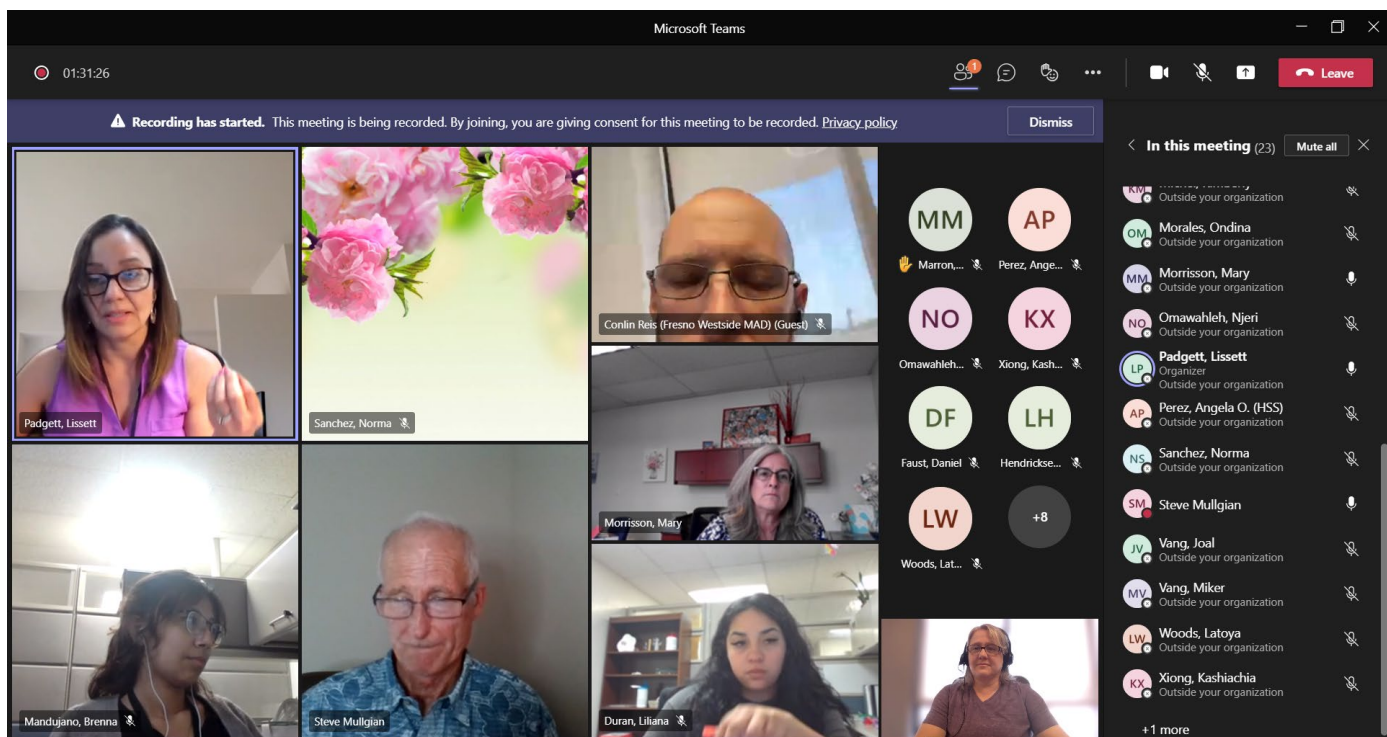

## Digital Outreach

During July, 1,118 people visited the District website. Of those who visited the website, 89% were new visitors.

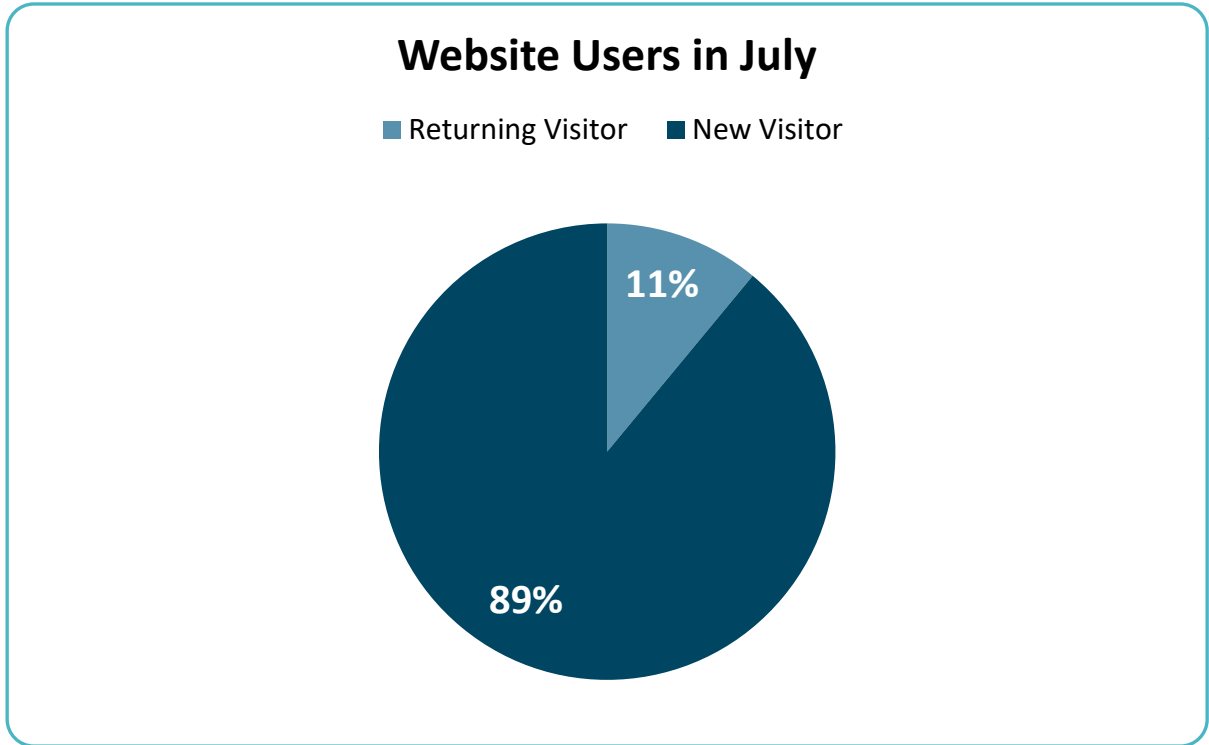

Website analytics is used to gather performance data about the education pages combined as compared to a combined look at the standard website pages.

<b>Category</b>	<b>Percentage of pages viewed from total pages viewed</b>	<b>Most viewed page in category</b>	<b>Percentage of time a visitor entered our website through a page</b>	<b>Average amount of minutes a visitor viewed content on a page</b>
Education website pages combined	19.18%	How to screen your yard drains	28%	1.30
Standard website pages combined*	80.82%	Homepage	72%	1.48

\*A standard web page would be a page that is not part of the education section, such as the homepage.

## Social Media

Social Media Platform	Number of Subscribers (change from previous month)	Number of posts	Engagement Rate
Facebook	385 (↑16)	15	8.4%
Twitter	229 (↑1)	10	4.4%
Nextdoor	106,643 (↑1075)	29	0.4%
Instagram	134 (↑3)	11	85.4%



# Nextdoor



## Digital Advertising

During July, the District boosted five posts on Facebook; 21% of website users came from Facebook; and “How to screen your yard drains” was the most popular website page viewed directly from Facebook.

Advertisement/boosted post topic*	Link clicks** (all)	CTR*** (all)	Cost per result^
<i>Boosted Post - Screen yard drains</i>	210	6.47%	\$0.17
<i>Boosted Post - Defend against mosquitoes</i>	441	3.61%	\$0.24
<i>Boosted Post - Personal protection</i>	89	2.64%	\$0.52
<i>Boosted Post - Mosquito Busters learning tool</i>	204	7.41%	\$0.11
<i>Boosted Post - Screen yard drains</i>	120	3.88%	\$0.41

\*An advertisement and a boosted post is content that is promoted by Facebook to users that do not follow our page.

\*\*The number of all clicks on the ad/post.

\*\*\*Click-Through Rate - the percentage of times people saw the ad/post and performed any type of click.

^The number of times the ad/post achieved an outcome, based on the objective and settings that were selected.



## Outreach Events

The District participates in events throughout the year. At each event, District staff will set up an informational table equipped with a mosquito life cycle display, mosquitofish swimming in a tank, plant pot source examples, yard drain tube with lid and screen example, kids shoes to show residents how to keep mosquitoes out of house, educational handouts, and logoed giveaways.

The District participated in an outreach event at The Fresno Discovery Center on July 3rd. The informational table (top right photo) was staffed by Science Education Coordinator, Katherine Ramirez and volunteer KD Ramirez. District staff engaged with approximately 15 families. Children in attendance enjoyed the mosquito life cycle bean bag toss game.

The District also participated in the “Healthy Fresno County” night at the Fresno Grizzly Baseball game on July 24th. The informational table was staffed by Science Education Coordinator, Katherine Ramirez and GIS Coordinator, Conner Schaak (page 2). Approximately 80 residents were engaged by staff. The District was welcomed by the game announcer while the District name was displayed on the jumbo screen (bottom right photo).

